

新視野，未來感

新能源新世代 2025

一年一度的中學生太陽能車比賽盛事 //
組別包括大車, 細車, 氫能車, 太陽能船及滑翔機



可載人太陽能車(大車) 工作坊一
初談高效節能設計

工作坊內容



01

1)初談高效節能設計

1月25日



02

車輛動力ABC

2月15日



03

電力驅動技術 I

3月15日



04

電力驅動技術 II

4月5日



05

車身設計大不同

5月17日



06

太陽能車攻略

7月13日



工作坊提要

1. 太陽能車介紹
2. 太陽能車賽事
3. 新能源新世代2025 大車賽例
4. 主要部件
5. 時間表
6. 能源管理計算

什麼是淨零(Net Zero)?

什麼是淨零(Net Zero)?

簡而言之，淨零意味著將溫室氣體排放量減少到盡可能接近零，任何剩餘的排放量都會從大氣中重新吸收，例如透過海洋和森林。[1]

淨零排放
#可能实现



淨零及可持續發展



圖1 Net-Zero Emissions by 2050 Scenario[2]

Sector	Year	Milestone
Industry	2020	• Global average plastics collection rate = 17%.
	2030	• Global average plastics collection rate = 27%. • Lightweighting reduces the weight of an average passenger car by 10%.
	2050	• Global average plastics collection rate = 54%. • Efficiency of fertiliser use improved by 10%.
Transport	2030	• Eco-driving and motorway speed limits of 100 km/h introduced. • Use of ICE cars phased out in large cities.
	2050	• Regional flights are shifted to high-speed rail where feasible. • Business and long-haul leisure air travel does not exceed 2019 levels.
Buildings	2030	• Space heating temperatures moderated to 19-20 °C on average. • Space cooling temperatures moderated to 24-25°C on average. • Excessive hot-water temperatures reduced.
	2050	• Use of energy-intensive materials per unit of floor area decreases by 30%. • Building lifetime extended by 20% on average.

Note: Eco-driving involves pre-emptive stopping and starting; ICE = internal combustion engine.

圖2 Key global milestones for behavioral change in the Net-Zero Emissions by 2050 Scenario[2]

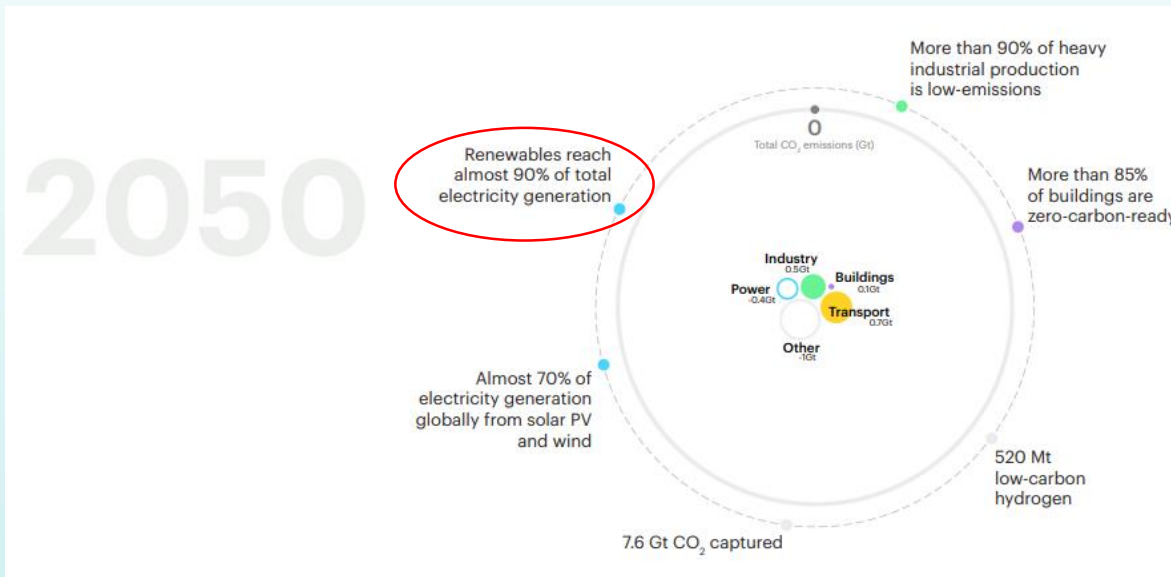
[2] Net Zero by 2050 A Roadmap for the Global Energy Sector(2021) International Energy Agency. 參考: https://iea.blob.core.windows.net/assets/deebef5d-0c34-4539-9d0c-10b13d840027/NetZeroby2050-ARoadmapfortheGlobalEnergySector_CORR.pdf (访问日期：18 Jan 2024).



淨零及可持續發展



圖3 Intelligent Energy Systems [3]



圖4 Smart Grid-EV integration framework[4]

[3] National Climate Change Secretariat and National Research Foundation (2011) Smart Grid Technology Primer: A Summary

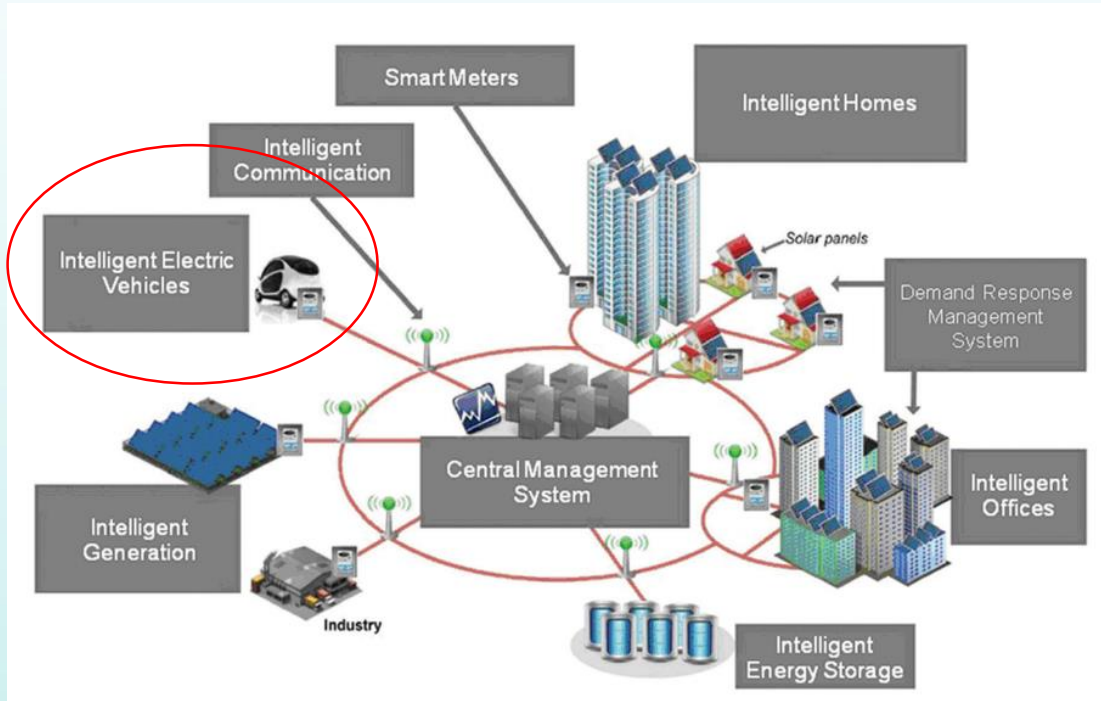
[4] Vivian S.(2022) Integration of EVs into the smart grid: a systematic literature review. California Statue University

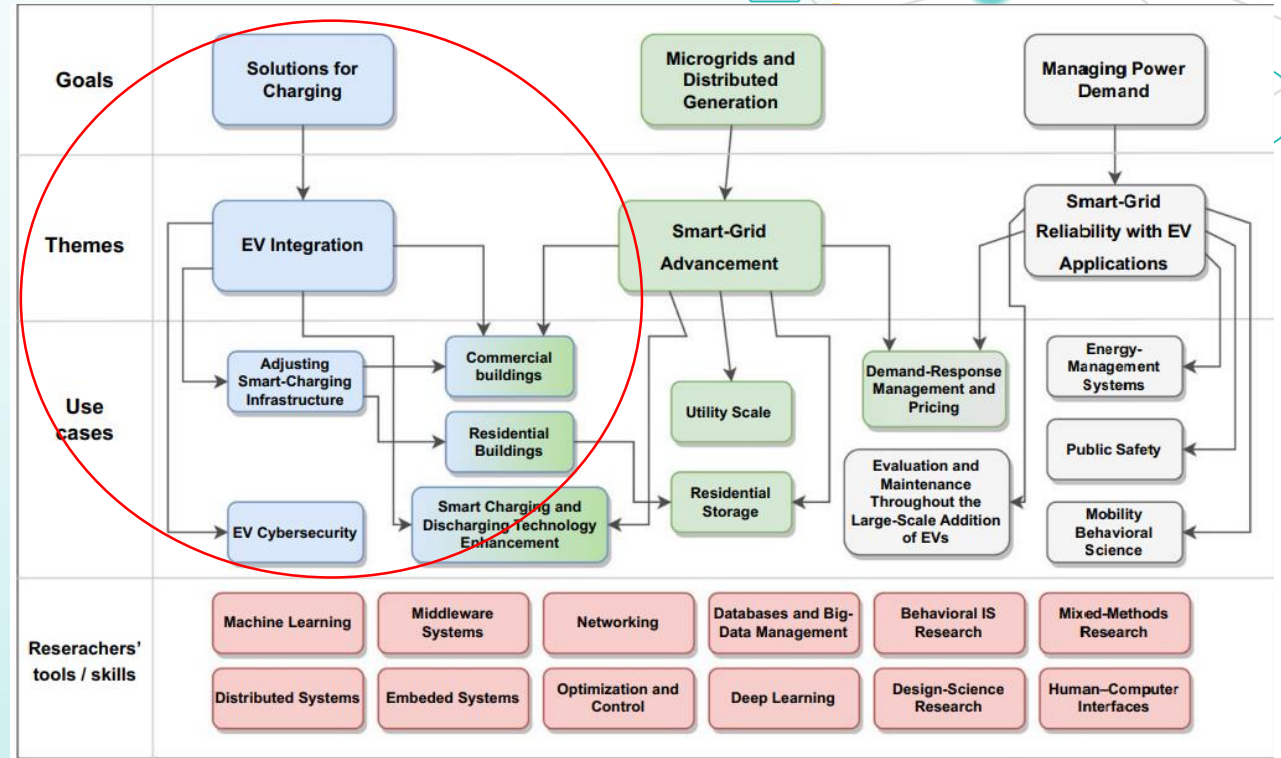

太陽能車萌芽及發展



1912年第一架太陽能車
Baker electric car[5]



1977年3輪式太陽能車
Bluebird solar car [5]



1982年太陽能車Quiet Achiever 首次在澳洲駕駛, 並在1987年開始世界太陽能車挑戰賽 [5]



2022年荷蘭車隊成員開始在芬蘭工廠製作商業用太陽能車Lightyear [6]

[5] Tathagata P. (2016) Electric Solar Vehicle – RayRacer. KIIT University

[6] World's first solar-powered electric car enters production (2022) Drive.com. 參考 <https://www.drive.com.au/news/worlds-first-solar-powered-electric-car-enters-production/> (訪問日期: 8 Jan 2024)

太陽能車賽事

- 世界太能車挑戰賽(Bridgestone World Solar Challenge)[7]
- 美國太陽能車挑戰賽(Electrek American Solar Challenge)[8]
- 南非太陽能車挑戰賽(South African Sasol Solar Challenge)[9]
- 歐洲太陽能車挑戰賽(iLumen European Solar Challenge)[10]
- Shell Eco-marathon Asia-Pacific and the Middle East[11]



[7] Bridgestone World Solar Challenge (2023) 參考: <https://worldsolarchallenge.org/> (訪問日期: 8 Jan 2024)

[8] Electrek American Solar Challenge (2023) 參考: <https://www.americansolarchallenge.org/> (訪問日期: 8 Jan 2024)

[9] South African Sasol Solar Challenge (2023) 參考: <https://www.solarchallenge.org.za/> (訪問日期: 8 Jan 2024)

[10] iLumen European Solar Challenge (2023) 參考: <https://www.europeansolarchallenge.eu/> (訪問日期: 8 Jan 2024)

[11] Shell Eco-marathon(2023) 參考: <https://www.shellecomarathon.com/> (訪問日期: 8 Jan 2024)

世界太陽能車挑戰賽



是一項旨在設計世界上最
高效的電動車的設計競賽。

兩年一度的活動旨在激勵世界各地的年輕人
解決永續的交通問題。

比賽分為兩個主要組別，代表了太陽能電動
車的多樣性和不同的設計概念。



世界太陽能車挑戰賽



Projecta Challenger Class

設計一座位太陽能車
速度取勝



CSIRO Cruiser Class

設計多於一座位太陽能車
能源效率取勝



Adventure Class

非競爭性的賽事



地點：零碳天地



重要日程：(初)



日期	活動
30/08 (六)	<ul style="list-style-type: none"> - 新能源新世代活動日-賽事日 - 與在澳州進行世界太陽能車挑戰賽的 VTC 太陽能車車隊 進行直播交流 - 邀請Shell Eco-Marathon 專家作分享及展出 - Smart city project display 及 Fun booth
31/08 (日)	<ul style="list-style-type: none"> - 新能源新世代活動日-太陽能車展示 - Smart city project display 及 Fun booth

VTC 太陽能車車隊

SOPHIE **VTC Solar Car Team**
@vtcsolarcarteam7058 · 120 subscribers · 25 videos
Since 2009, IVE Engineering staff and students have been working ...
Subscribed



https://www.youtube.com/watch?v=K4V_mbgZp-w

設計要求

- 整體車身尺寸
- 座位數量
- 車輪數量
- 太陽能板規格及種類
- 電池容量
- 安全
- 煞車及轉向系統
- 等等

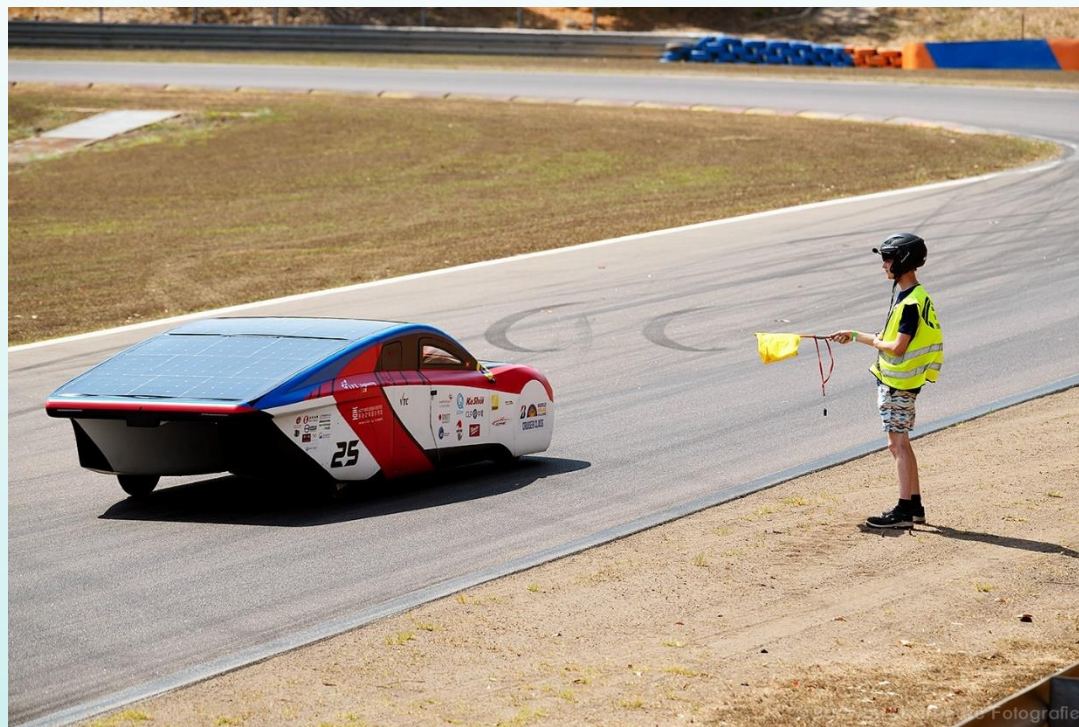

新視野，未來感

新能源新世代 2025

一年一度的中學生太陽能車比賽盛事 //
組別包括大車, 細車, 氫能車, 太陽能船及滑翔機



可載人太陽能車(大車) 工作坊一
初談高效節能設計

“車”從何來？

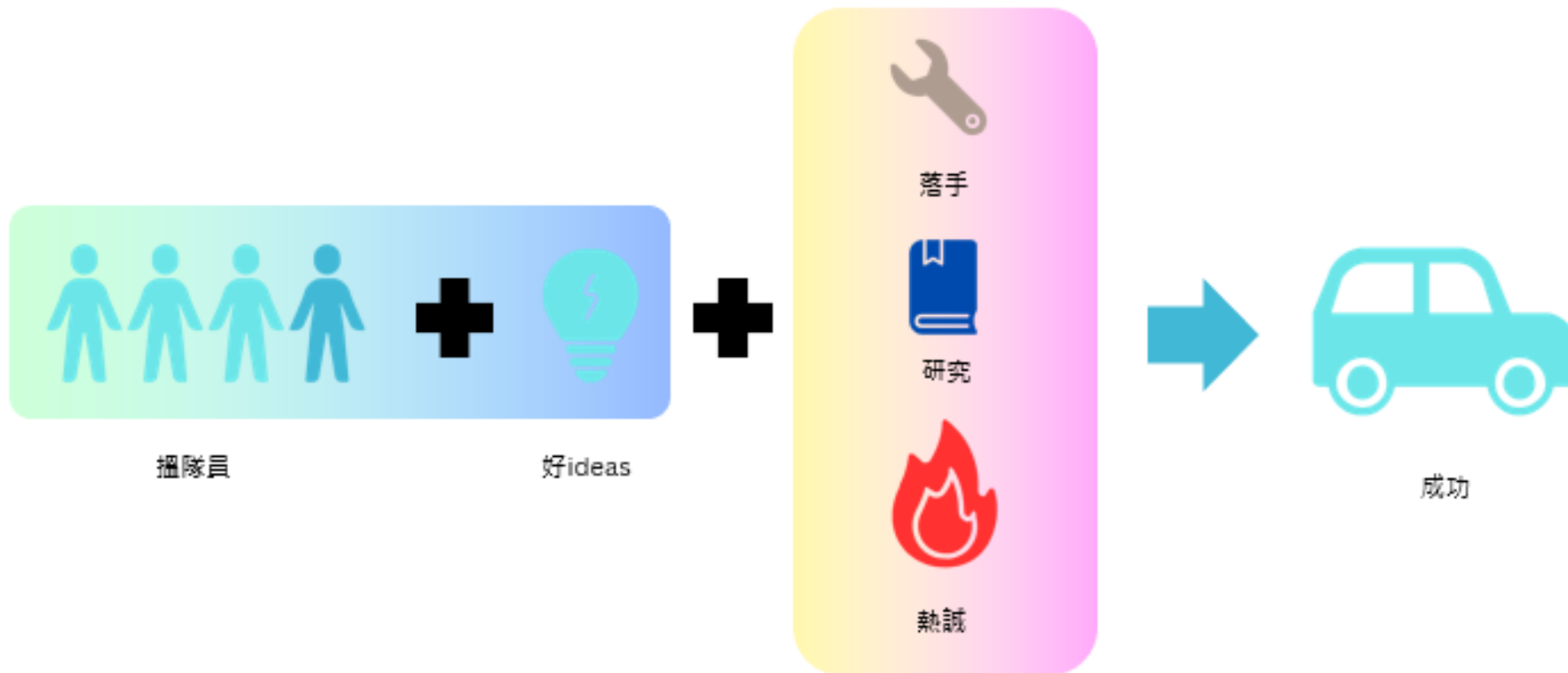

“車”從何來？

整車要求 🧐
查閱比賽賽例



New Energy New Generation 2025

Prepared for Rideable Solar Car Class

Technical Regulation



- 重點更新(2025):
- Off-track award 需通過所有車檢的車隊
 - 大會將提供新焦耳計 Joulemeter
 - 決賽安排

車身要求

要求	詳細
車身尺寸：	長度：2.2m – 3.5m 寬度：1.2 m – 1.3 m 高度：1.0m – 1.3m 重量(最大容許)：225公斤 (淨太陽能車, 不包括司機)
座位數：	-僅限單人座位
輪子數量：	3-4輪



電力要求

- 電池容量
- 車內空間
- 安全
- 車指示燈
 - 2個頭燈
 - 2個前方向燈和2個後方向燈
 - 2個紅色後煞車燈和2個紅色後行車燈
- 車輛裝備
 - 車輛喇叭
 - 座艙
 - 安全帶
 - 急停制
 - 焦耳計
 - 安全設備
- 煞車及轉向系統



常見問題

- 節錄自2024年車檢後回饋

車隊探訪 團隊總結

- 大部份車隊準備理想, 都能夠買相關重要部件開始製作
- 電機部份:
 - 需要有電圖紙
 - BMS 及 相關說明書
 - 電壓需在48V 額定值 (包括馬達)
 - 太陽能板需在車頂
 - 電燈系統可以另外的副電提供能源



車隊探訪 團隊總結

- 機械部份:
 - 需有車門
 - 安全帶為5點
 - Rollbar & Bulkhead
 - Braking 需要有2套
- 整體安全:
 - 司機需16歲或以上
 - Driver log for >10 hr
 - Radio, Fire extinguisher



重要日期	活動
2025年1月25日	賽事條例文件發放
2025年1月25日前	招募隊員及報名活動
第一次工作坊後	準備採購清單及為隊員們分工合作
2025年4月期間	復活節假期 – 開工 (I)
2025年7月至8月期間	暑假 – 開工 (II)
2025年7月中	提交太陽能車文件及Off-track award申請 及 車隊探訪
2025年8月25日	賽前測試日
2025年8月27日	初賽
2025年8月30日	比賽日及頒獎禮

可載人太陽能車(大車)

延長報名限期至2月14日(新年後)

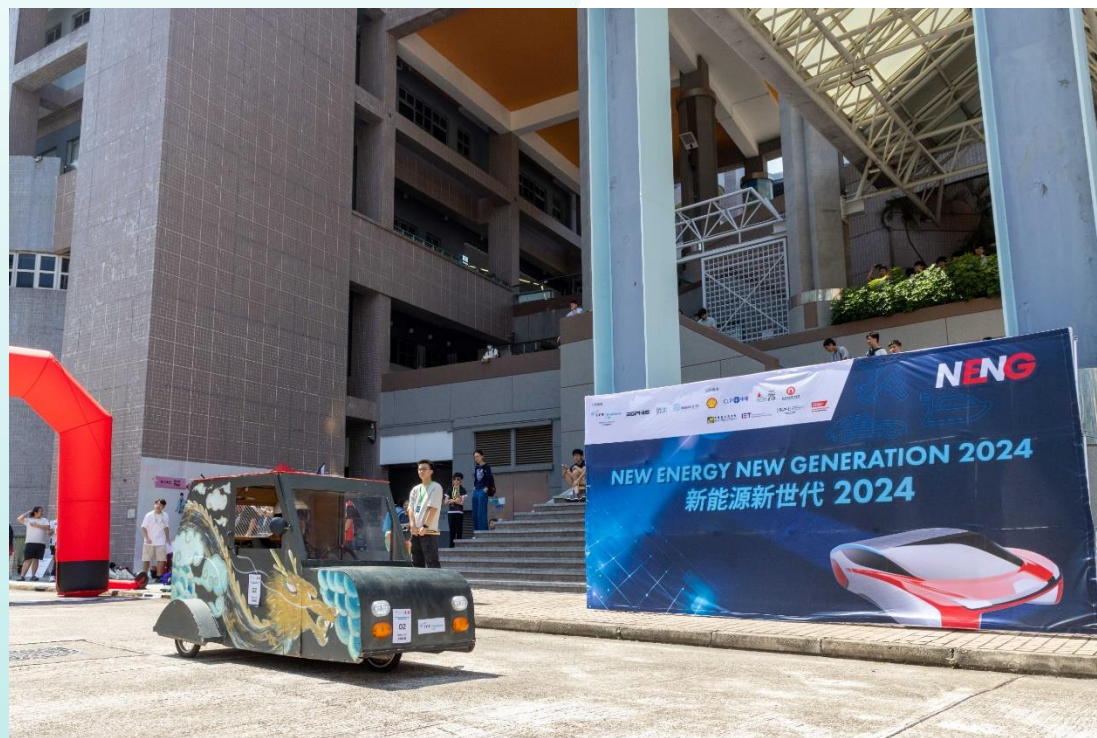



時間表

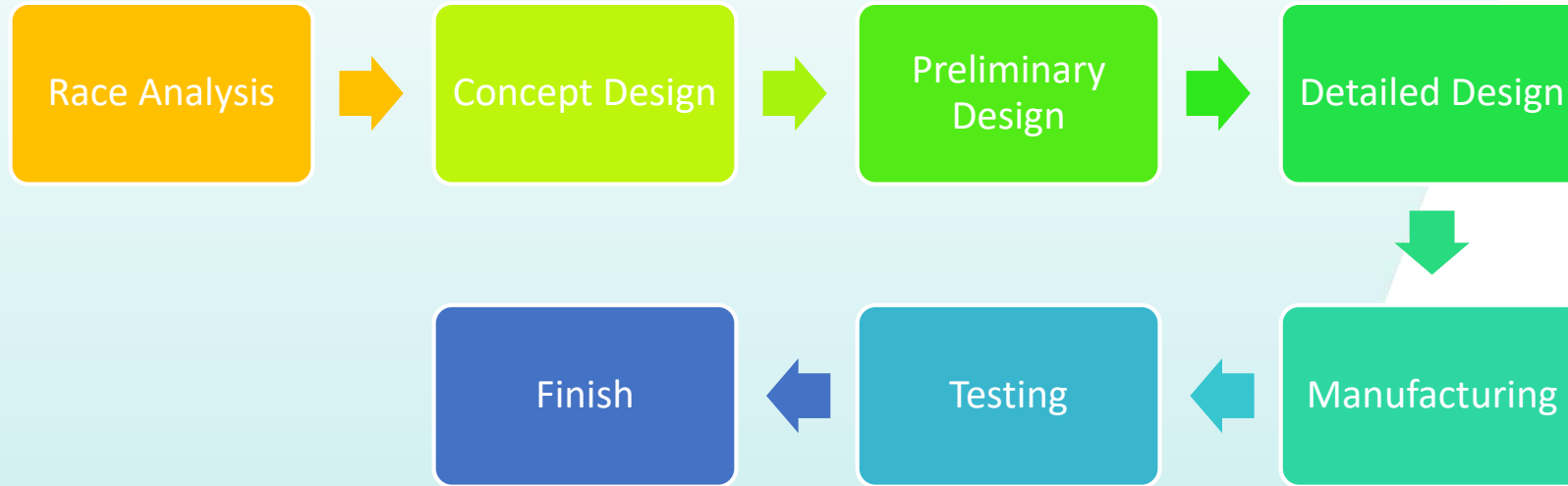

主要部件

-電力系統
-機械系統
-設備

	重要部件
1	車身結構 Bodyshell
2	車架及車內防滾架 Chassis and Rollbar
3	車輪和輪胎 Wheels and tires
4	煞車系統 Braking system
5	安全帶 Safety belts
6	馬達 Motor
7	太陽能板 Solar Panel
8	電池組 Battery pack
9	車指示燈 Lighting
10	車輛喇叭 Horn
11	通訊 Radio
12	滅火器 Fire Extinguisher

主要部件

太陽能車

使用太陽能進行車載充電

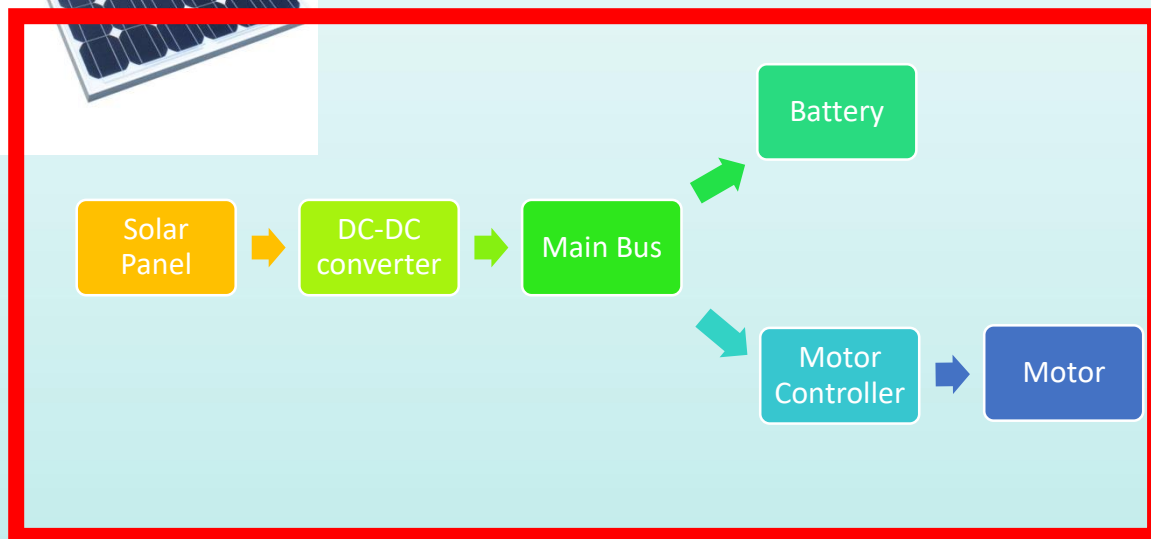
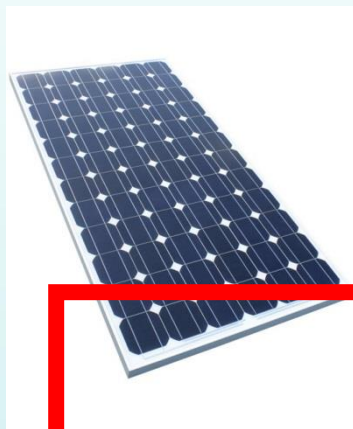

空氣動力

當速度達到 75 公里/小時時，由於空氣動力阻力，約 50% 的能量消耗

Percent aerodynamic drag to total power usage

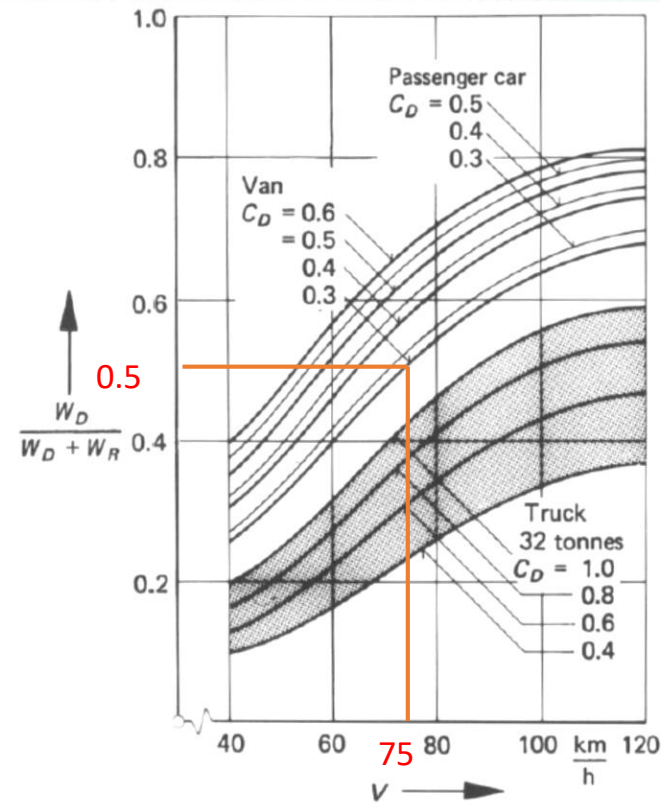



如何減少阻力

Shape		Drag Coefficient
Sphere	→ ○	0.47
Half-sphere	→ ◐	0.42
Cone	→ ▲	0.50
Cube	→ □	1.05
Angled Cube	→ ◊	0.80
Long Cylinder	→ ▭	0.82
Short Cylinder	→ ◻	1.15
Streamlined Body	→ ◡	0.04
Streamlined Half-body	→ ◡	0.09

Measured Drag Coefficients

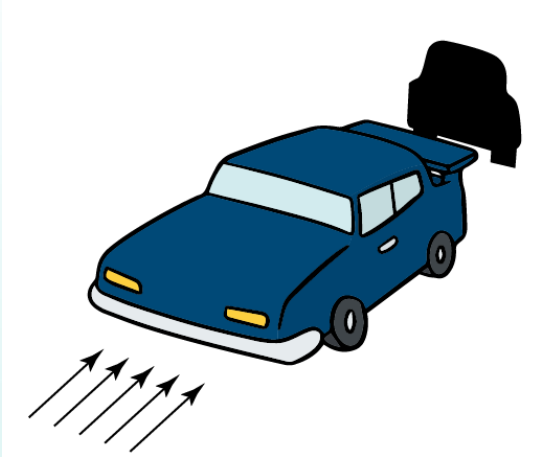

Frontal Projected Area

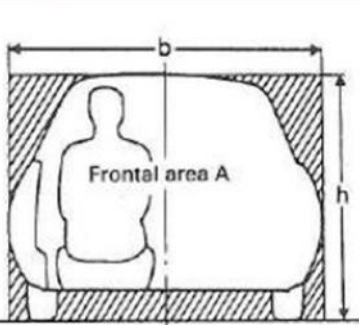

Car Class	Frontal area A m ²
mini	1.8
medium size	1.9
upper medium size	2.0
full size	2.1

$A \approx 0.81 \cdot (b \cdot h)$



空氣動力學發展

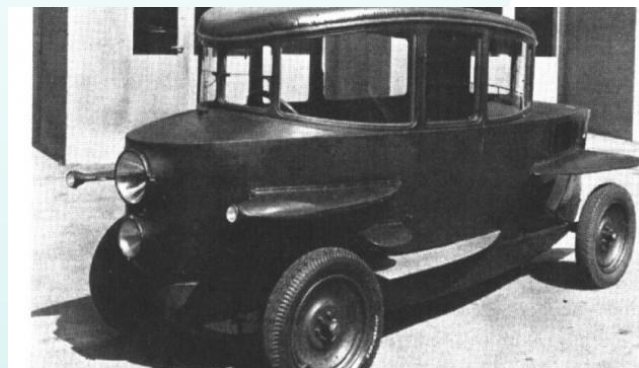
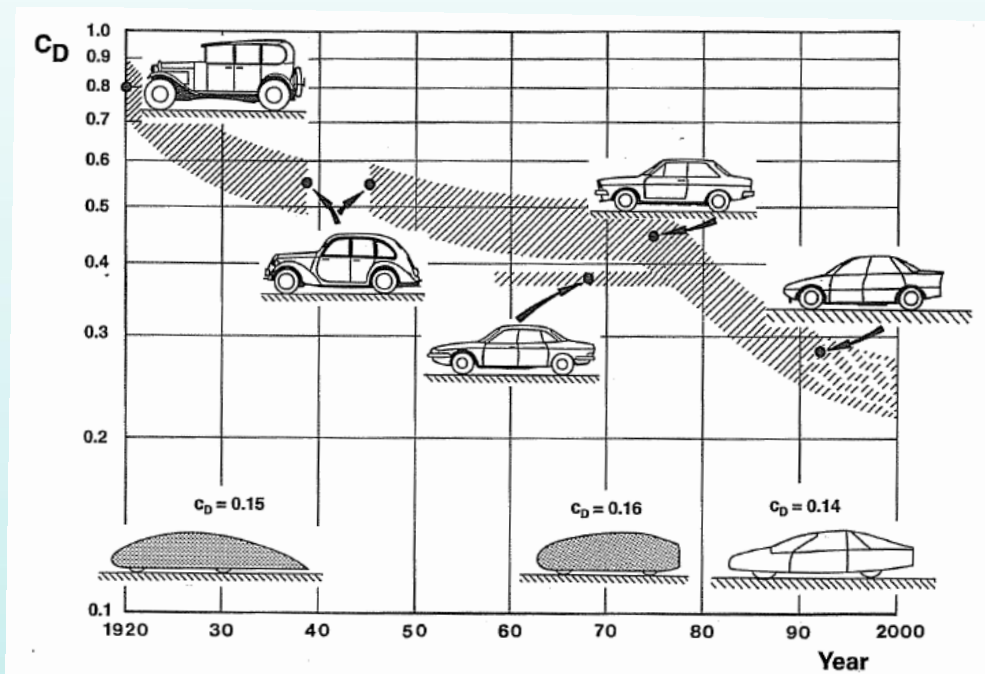

The Most Aerodynamic Cars

#1 Volkswagen XL1



Drag coefficient

0.19

#2 Tesla Model 3



Drag coefficient

0.21

潛在困難

Cd值是指風阻係數。當流體在物體周圍流動時物體所受到的阻力。Cd值用於量化車輛的空氣動力效率。Cd值越低表示空氣動力學性能越好，物體受到的阻力較小，克服空氣阻力所需的能量也較少。Cd值通常用於汽車工業，以優化車輛設計並提高燃油效率。

然而，要獲得準確的Cd值並不容易...



風洞測試
(Wind Tunnel Test)

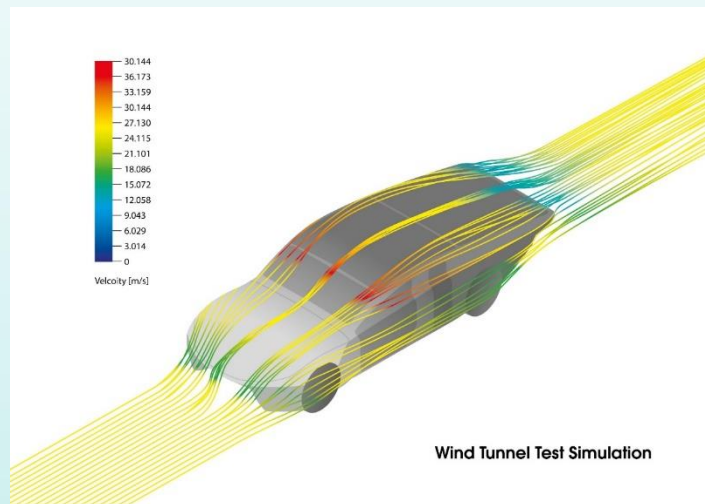

計算流體動力學
(Computational Fluid Dynamics)

小休



主要部件

在建造太陽能車之前，要做什麼？

- 車殼?
- 電力系統?
- 機械系統?

	重要部件
1	車身結構 Bodyshell
2	車架及車內防滾架 Chassis and Rollbar
3	車輪和輪胎 Wheels and tires
4	煞車系統 Braking system
5	安全帶 Safety belts
6	馬達 Motor
7	太陽能板 Solar Panel
8	電池組 Battery pack
9	車指示燈 Lighting
10	車輛喇叭 Horn
11	通訊 Radio
12	滅火器 Fire Extinguisher



能源應用

輸入功率
Input Power

太陽能板→電池→馬達



輸出功率
Output Power

滾動阻力
空氣阻力
加速



行車考慮

空氣阻力 →

滾動阻力 →

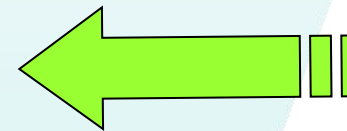

加速

力學

- a) 滾動阻力 Rolling Resistance
- b) 空氣阻力 Wind Resistance
- c) 加速 Acceleration
- d) 上坡 Climbing(Gradient)

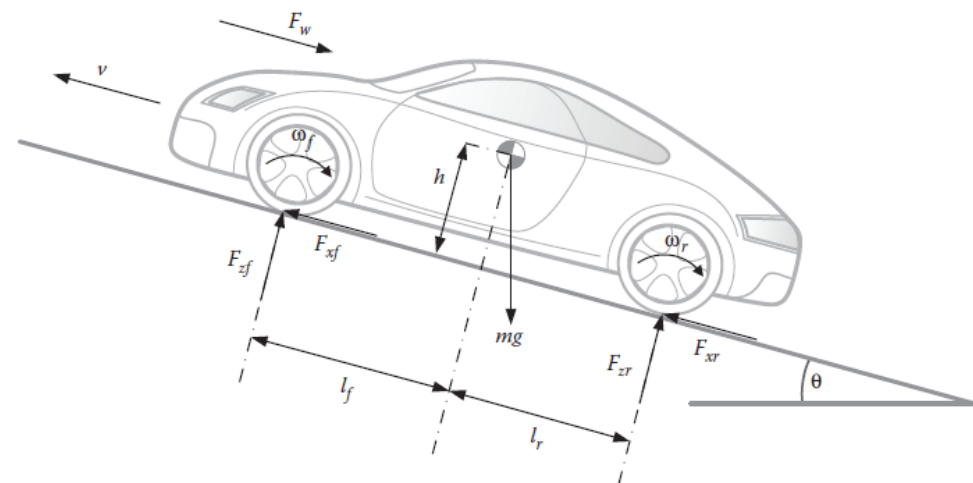
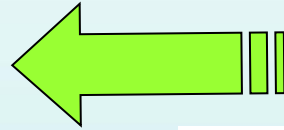
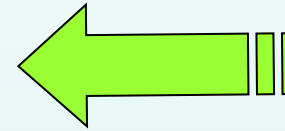

滾動阻力

滾動阻力是指騎乘時需要施加的力量，以克服不屬於傳動系統的自行車零件所產生的機械阻力。

當開車時，這些零件會移動，包括輪胎與路面之間的摩擦。為了減少滾動阻力，您可以確保輪胎沒有充氣不足。

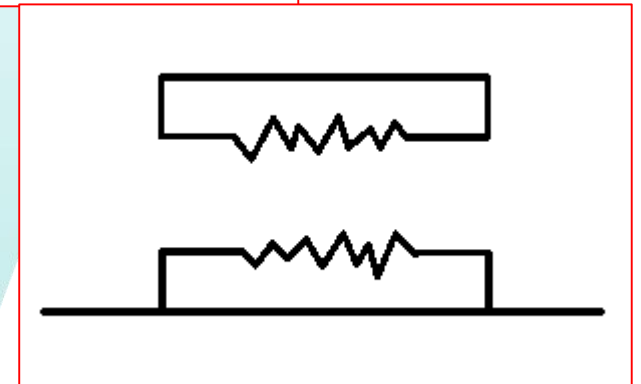
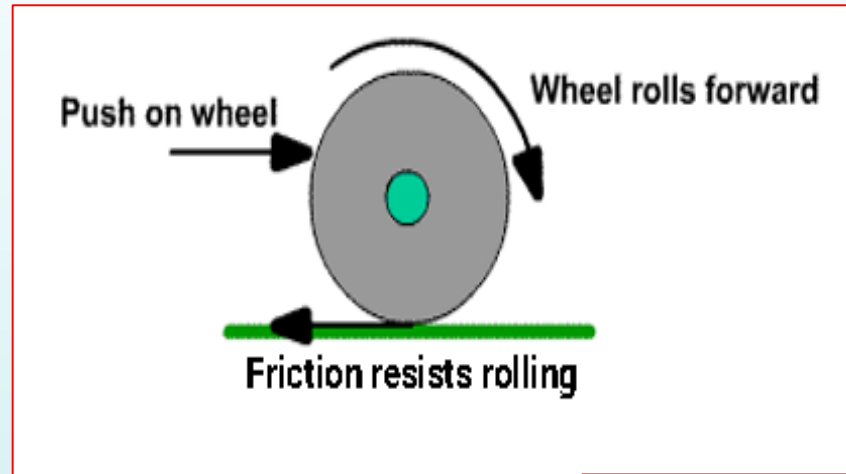

滾動阻力

$$F = \mu_{rolling} \times m \times g$$

*Force(rolling) = Force used to cover
the rolling resistance when the car is driving*

Unit = N

$\mu(rolling)$ = Rolling coefficient of friction

m = mass of person and solar car

Weight of driver and solar car

Unit = kg

g = acceleration of gravity,
directed downwards

10N/kg



滾動阻力

Rolling Resistance Coefficient		
<i>c</i>	<i>c_r</i> (mm)	
0.001 - 0.002	0.5	railroad steel wheels on steel rails
0.001		bicycle tire on wooden track
0.002 - 0.005		low resistance tubeless tires
0.002		bicycle tire on concrete
0.004		bicycle tire on asphalt road
0.005		dirty tram rails
0.006 - 0.01		truck tire on asphalt
0.008		bicycle tire on rough paved road
0.01 - 0.015		ordinary car tires on concrete, new asphalt, cobbles small new
0.02		car tires on tar or asphalt
0.02		car tires on gravel - rolled new
0.03		car tires on cobbles - large worn
0.04 - 0.08		car tire on solid sand, gravel loose worn, soil medium hard
0.2 - 0.4		car tire on loose sand

空氣阻力

Any object moving through a fluid experiences drag - the net force in the direction of flow due to pressure and shear stress forces on the surface of the object

$$F_d = c_d \cdot \frac{1}{2} \rho v^2 A$$

where

F_d = drag force (N)

c_d = drag coefficient

ρ = density of fluid (1.2 kg/m³ for air at NTP)

v = flow velocity (m/s)

A = characteristic frontal area of the body (m²)

Shape	Drag Coefficient
Sphere	0.47
Half-sphere	0.42
Cone	0.50
Cube	1.05
Angled Cube	0.80
Long Cylinder	0.82
Short Cylinder	1.15
Streamlined Body	0.04
Streamlined Half-body	0.09

Measured Drag Coefficients

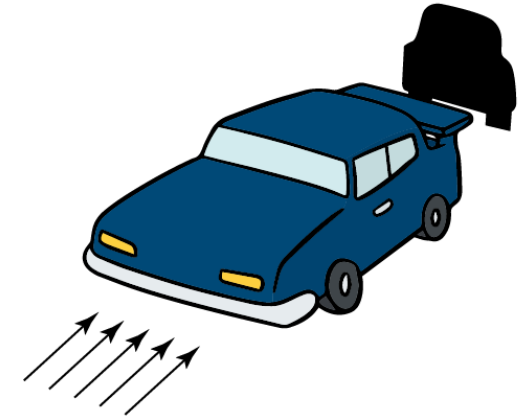

Car Class	Frontal area A m ²
mini	1.8
medium size	1.9
upper medium size	2.0
full size	2.1

$A = 0.81 \cdot (b \cdot h)$



加速

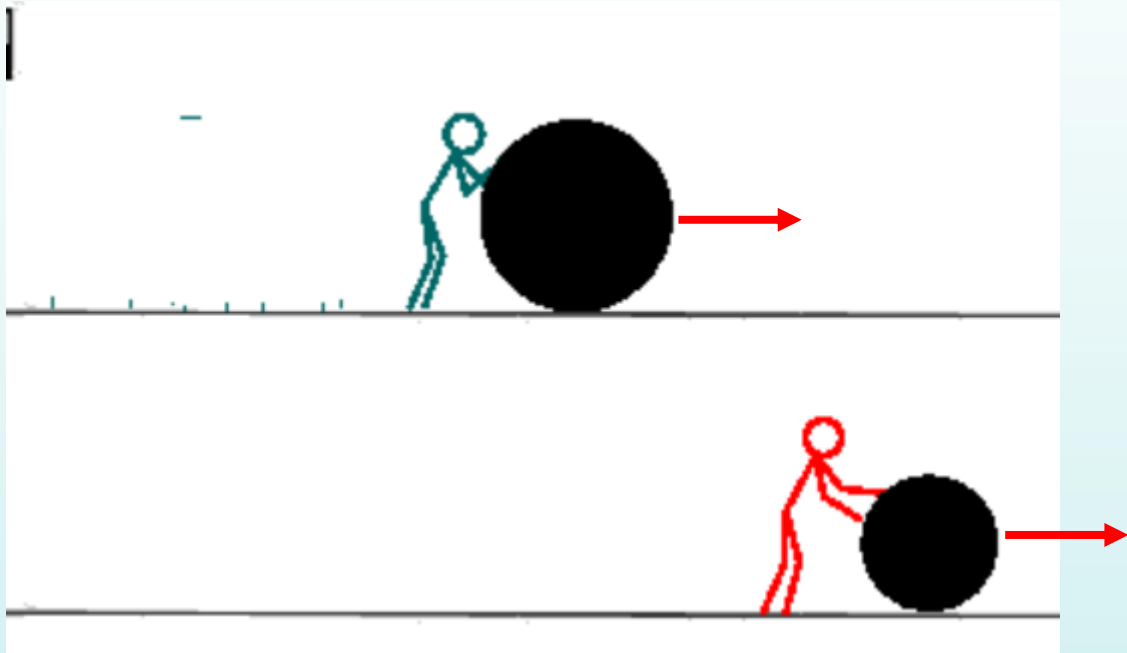

$$Force (accel) = m \times a$$

Equation for average acceleration

$$a = \frac{\Delta v}{\Delta t}$$

m is mass (*m*)

a is acceleration ($\frac{m}{s^2}$),

Δv is the change in velocity,

Δt is the amount of time it took for that change to occur



加速

$$Force (accel) = m \times a$$

$\Delta v = v_f - v_i$
 $\Delta t = t_f - t_i$

v_f → final velocity
 v_i → initial velocity
 t_f → ending time
 t_i → starting time

equation for average acceleration

Velocity = Car speed = $\frac{distance}{time}$
Unit normal in km/h



加速

$$Force (accel) = m \times a$$

Example:

$$\Delta v = v_f - v_i$$

$$\Delta t = t_f - t_i$$

v_f → final velocity
 v_i → initial velocity
 t_f → ending time
 t_i → starting time

Ex. 1

$$v_f = 46.1 \text{ m/s}$$

$$v_i = 18.5 \text{ m/s}$$

$$t_f = 2.47 \text{ s}$$

$$t_i = 0 \text{ s}$$

$$a = \Delta v / \Delta t$$

$$= (v_f - v_i) / (t_f - t_i)$$

$$= \frac{46.1 \text{ m/s} - 18.5 \text{ m/s}}{2.47 \text{ s} - 0 \text{ s}}$$

$$= 11.17 \text{ m/s}^2$$

Ex. 2

$$v_f = 0 \text{ m/s}$$

$$v_i = 22.4 \text{ m/s}$$

$$t_f = 2.55 \text{ s}$$

$$t_i = 0 \text{ s}$$

$$a = \Delta v / \Delta t$$

$$= (v_f - v_i) / (t_f - t_i)$$

$$= \frac{0 \text{ m/s} - 22.4 \text{ m/s}}{2.55 \text{ s} - 0 \text{ s}}$$

$$= -8.78 \text{ m/s}^2$$



功率使用

$$Power = (Force(rolling) + Force(accel)) \times Velocity$$

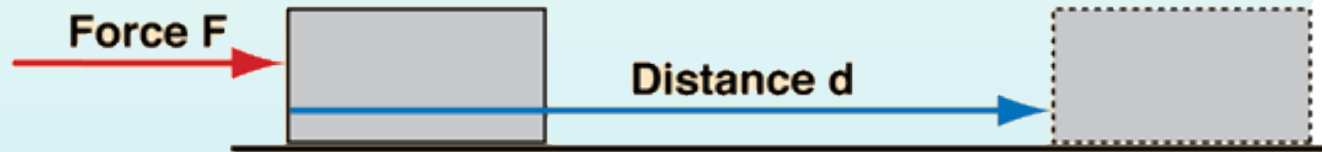

Work = Force x distance moved in direction of force

Work
concepts

$$P_{avg} = \frac{Work}{time} = \frac{Force \times distance}{time}$$

Special case for constant force acting in the direction of motion.

行車速度

Find N (rpm of the wheel):

$$V = r \times \omega$$

$$V = \text{linear velocity} = \frac{\text{distance}}{\text{time}} = \frac{dS}{dt}$$

ω = angular velocity (rate of change of angular displacement)

Since our displacement/distance is the length of the arc which is made by the angle $d\theta$: $s = rd\theta$

$$V = \frac{rd\theta}{dt}, \omega = \frac{d\theta}{dt}, \text{ r is the radius of wheel}$$

扭力

Torque (Nm needed at the wheel)

$$P = T \times \omega$$

P= Power (W)

T= Torque from the wheel

ω =angular velocity (rate of change of angular displacement)



覆數

$$P = (Force(rolling) + Force(accel)) \times Velocity$$

$$P = T \times \omega$$

$$\omega = \frac{V}{r}$$

$$P = T \times \frac{V}{r}$$

$$T = P \times \frac{r}{V}$$

Should be the same result with previous slide!

$$T = (Force(rolling) + Force(accel)) \times V \times \frac{r}{V}$$

Torque = (Force(rolling) + Force(accel)) x r (radius of the wheel)

能源所需

決定馬達符合太陽能車需求:

功率
扭力
行駛速度



關鍵問題

- 1) 1輛太陽能車的關鍵因素是什麼？
- 2) 您的設計是為了速度還是耐力？

活動問卷

講比我地聽



新能源新世代2025 活動問卷



下堂主題

車輛動力ABC

數學與工程設計之間的連結；

驅動力、摩擦力和慣性；

四輪定位和測量；

輪子的速度和加速

Time to design the electrical system for your car

Rideable Solar Car Electrical System Outline

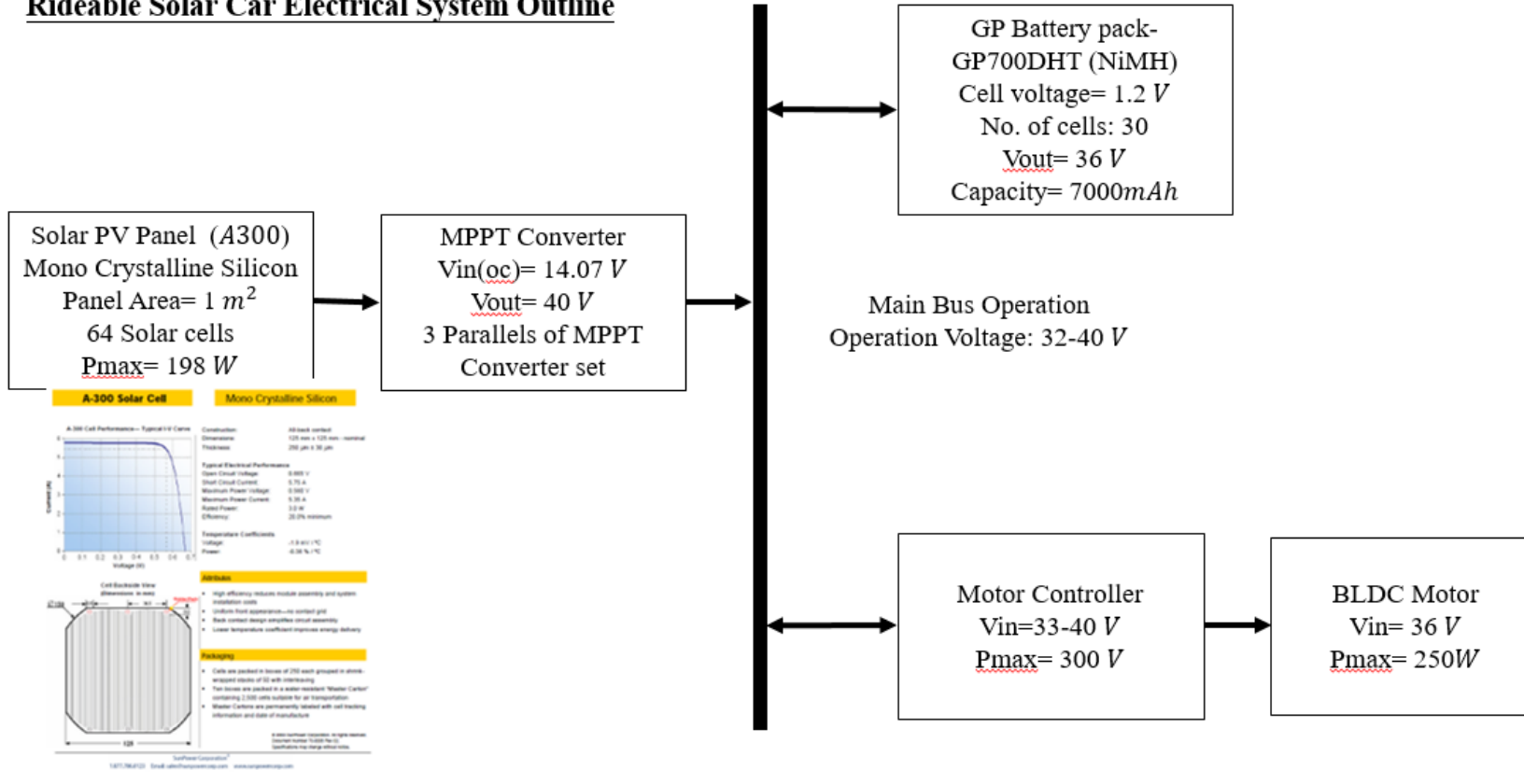



VTC



金蛇賀歲
吉祥平安

YEAR OF THE SNAKE