



NEW ENERGY  
**新能源** NEW  
GENERATION  
**2026 新世代**

全港一年一度的中學生太陽能車比賽盛事

可載人太陽能車(大車) 工作坊二  
車輛動力ABC

## 2026工作坊內容

**01**

1)初談高效節能設計  
1月31日

**02**

車輛動力ABC  
2月28日

**03**

電力驅動技術 I  
3月14日

Shell Nxplorers Programme - 5月尾

**04**

車身設計大不同  
5月23日

**05**

太陽能車攻略  
7月4日

**06**

技術支援 網上直播  
7月25日





# 2026 SHELL NXPLORERS PROGRAMME

## ALERT!



## TO RIDERABLE SOLAR CAR TEAM

CLASS A:

- 23/5/2026 (10:00AM - 5:00PM)
- 24/5/2026 (10:00AM - 1:00PM)

CLASS B:

- 30/5/2026 (10:00AM - 5:00PM)
- 31/5/2026 (10:00AM - 1:00PM)



	學校名稱	
1	新界鄉議局大埔區中學	A
2	嗇色園主辦可譽中學暨可譽小學	
3	靈糧堂劉梅軒中學	
4	獅子會蔣翠琮中學	
5	元朗公立中學	
6	樂善堂顧超文中學	
7	香海正覺蓮社佛教正覺中學	
8	東華三院邱金元中學	
9	裘錦秋中學(元朗)	
10	香港四邑商工總會陳南昌紀念中學	
11	聖公會聖西門呂明才中學	
12	聖若瑟書院	
13	嶺南鍾榮光博士紀念中學	
14	東華三院馮黃鳳亭中學	B
15	嗇色園主辦可藝中學	
16	地利亞修女紀念學校(吉利徑)	
17	保良局馬錦明夫人章馥仙中學	
18	馬鞍山崇真中學	
19	香港布廠商會朱石麟中學	
20	林大輝中學	
21	天主教郭得勝中學一隊	
22	天主教郭得勝中學二隊	
23	鳳溪第一中學	
24	瑪利諾中學	
25	樂善堂梁植偉紀念中學	



## 關鍵問題

- 1) 1輛太陽能車的關鍵因素是什麼？
- 2) 您的設計是為了速度還是耐力？

# 主題

## 車輛動力ABC

- 1) 車輛動力
- 2) 車架及車內防滾架 介紹
- 3) 煞車系統
- 4) 太陽能板發展

# 力學



a) 滾動阻力 Rolling Resistance



b) 空氣阻力 Wind Resistance



c) 加速 Acceleration



d) 上坡 Climbing(Gradient)



## 如何減少能源消耗

滾動阻力：

重量輕

車軸軸承/細輪胎

繞組電阻：

額面積小

光滑的形狀

加速度：

重量輕

哪種車身最快？

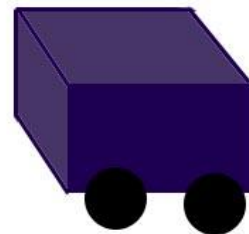

## 如何減少能源消耗

# 5 個 設計太陽能車 的技巧

1. 減少正面面積
2. 減低摩擦
3. 讓表面變得光滑
4. 減重
5. 太陽能板安裝

## 主要部件

在建造太陽能車之前，要做什麼？

- 車殼?
- 電力系統?
- 機械系統?

### 重要部件 Important Parts

- 1 車身結構 Bodyshell
- 2 車架及車內防滾架 Chassis and Rollbar
- 3 車輪和輪胎 Wheels and tires
- 4 煞車系統 Braking system
- 5 安全帶 Safety belts
- 6 馬達 Motor
- 7 太陽能板 Solar Panel
- 8 電池組 Battery pack
- 9 車指示燈 Lighting
- 10 車輛喇叭 Horn
- 11 通訊 Radio
- 12 滅火器 Fire Extinguisher



機械部件

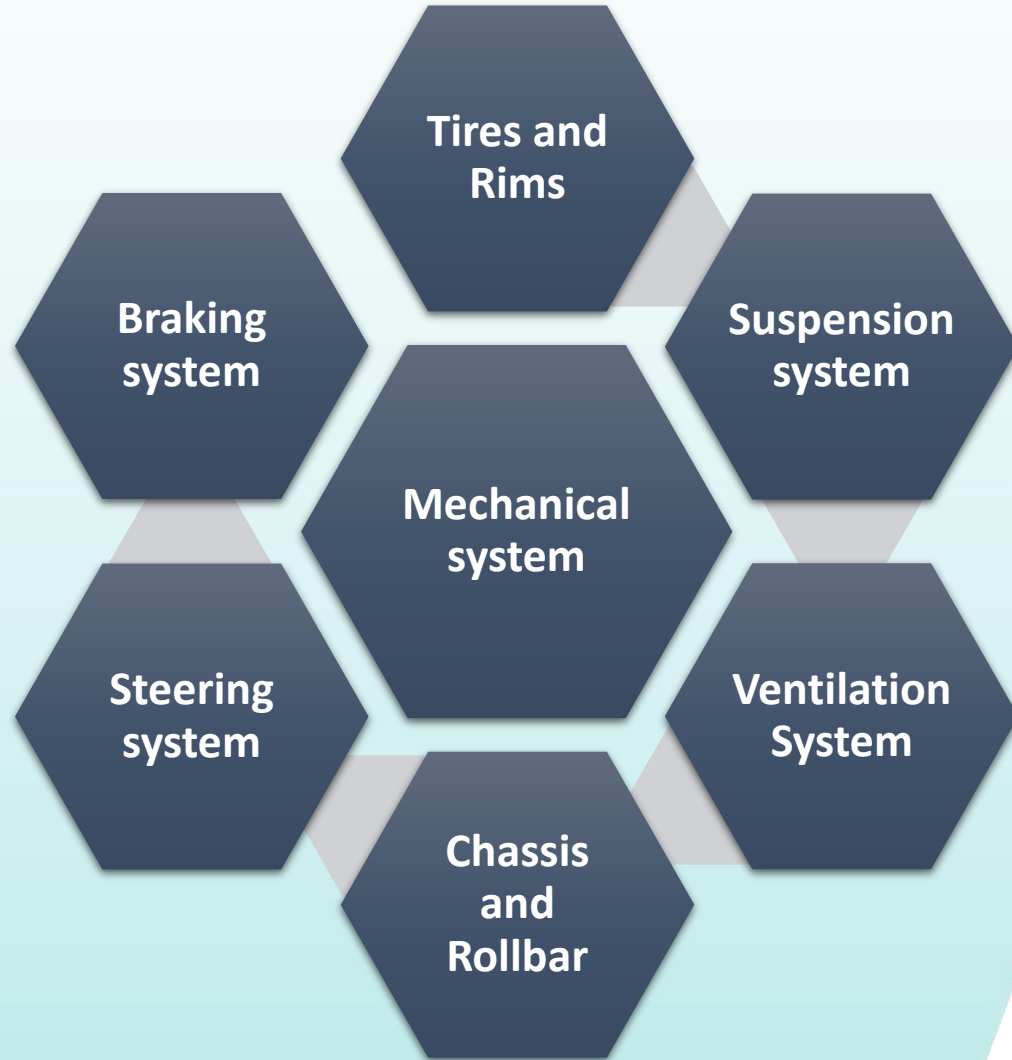

## 車架及車內防滾架 Chassis and Rollbar

- 車架是車的重要結構
- 具有各種機械部件的框架，如煞車、轉向和車輪
- 由輕金屬或複合材料製成，提供支撐車輛部件和負載所需的強度

# 車架及車內防滾架 Chassis and Rollbar

## Monique Chassis

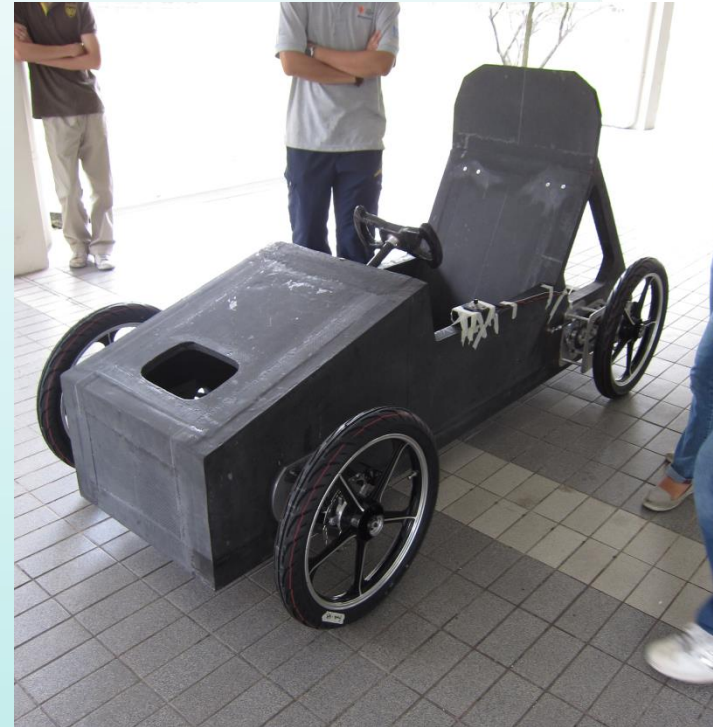

## 車架及車內防滾架 Chassis and Rollbar

# 三輪車 (Recumbent Trike)

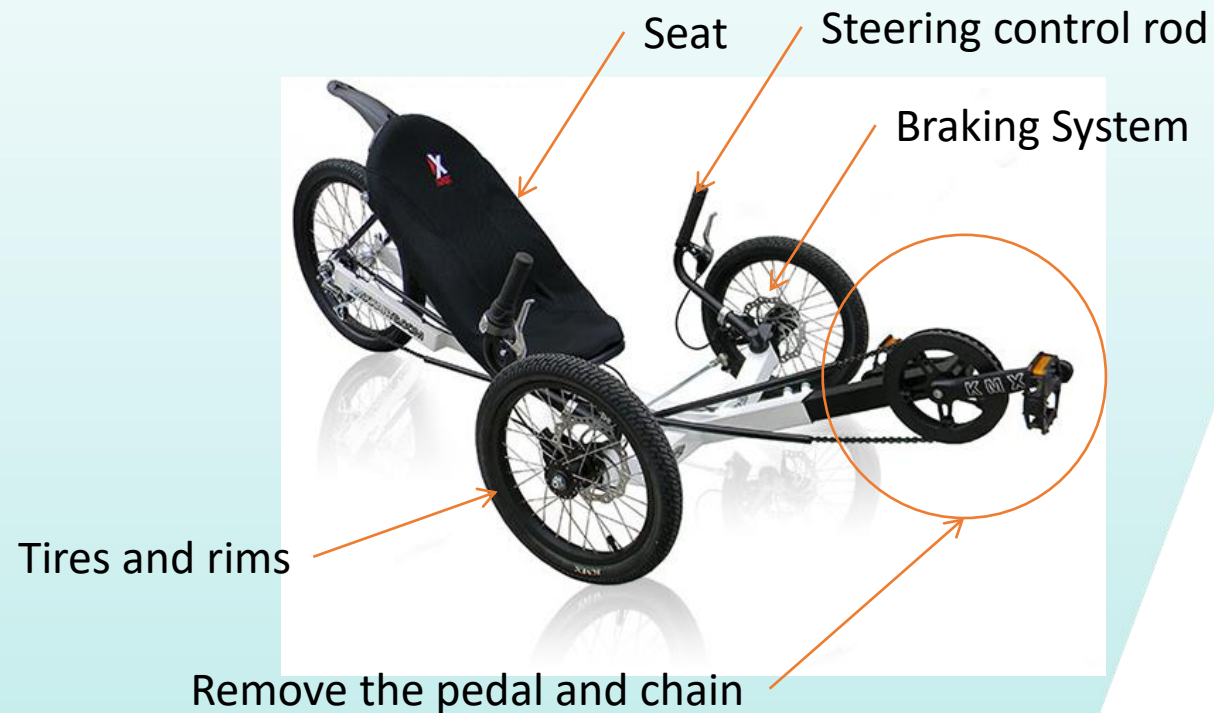

# 車架及車內防滾架 Chassis and Rollbar





# 車架及車內防滾架 Chassis and Rollbar

## 尺寸 Dimensions

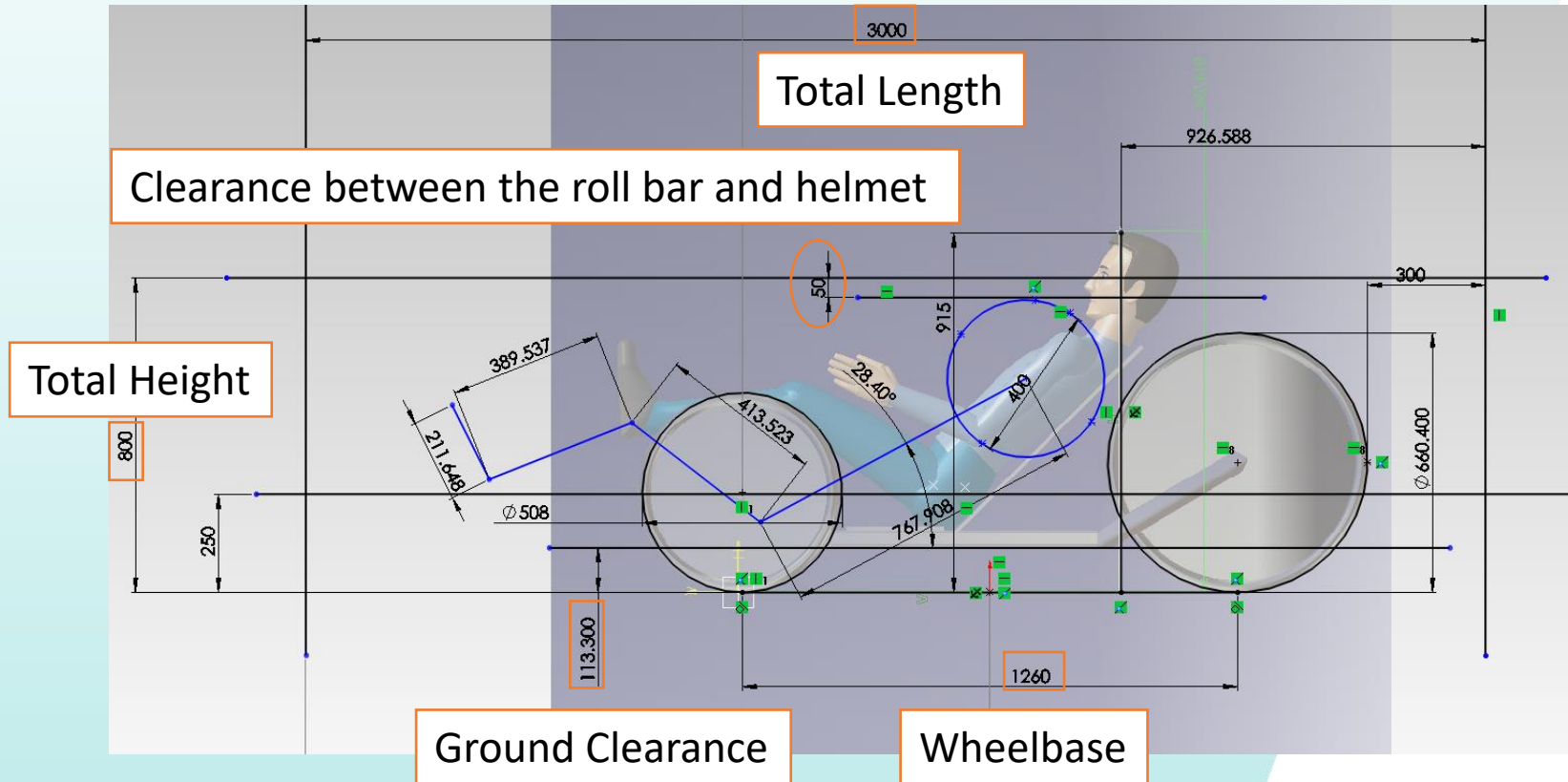



# 車架及車內防滾架 Chassis and Rollbar

## 尺寸 Dimensions

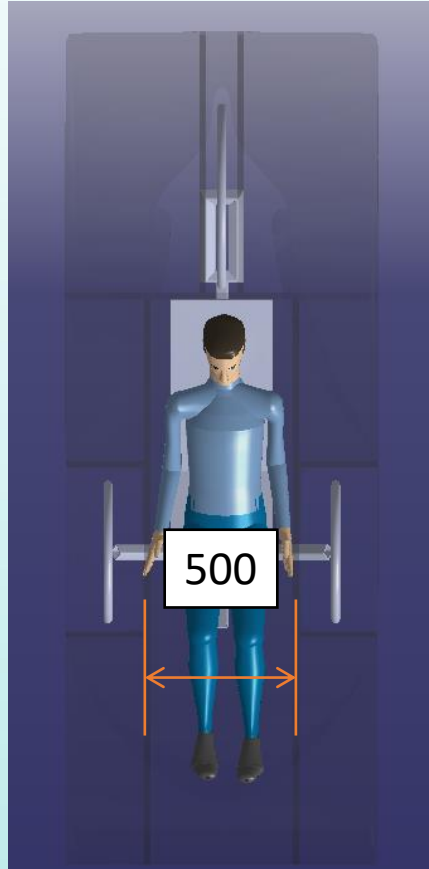
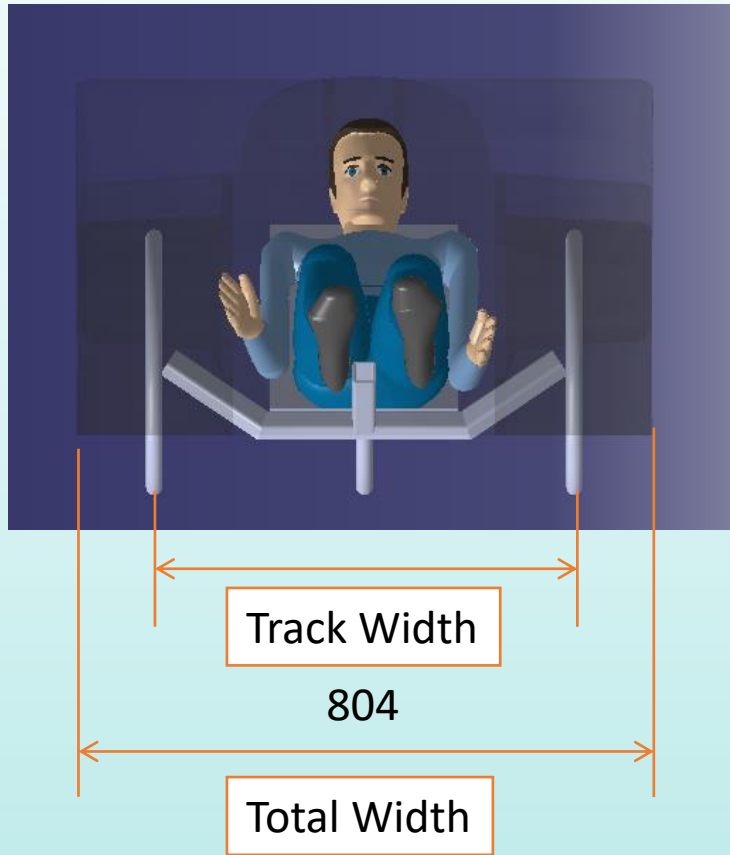



# 車架及車內防滾架 Chassis and Rollbar

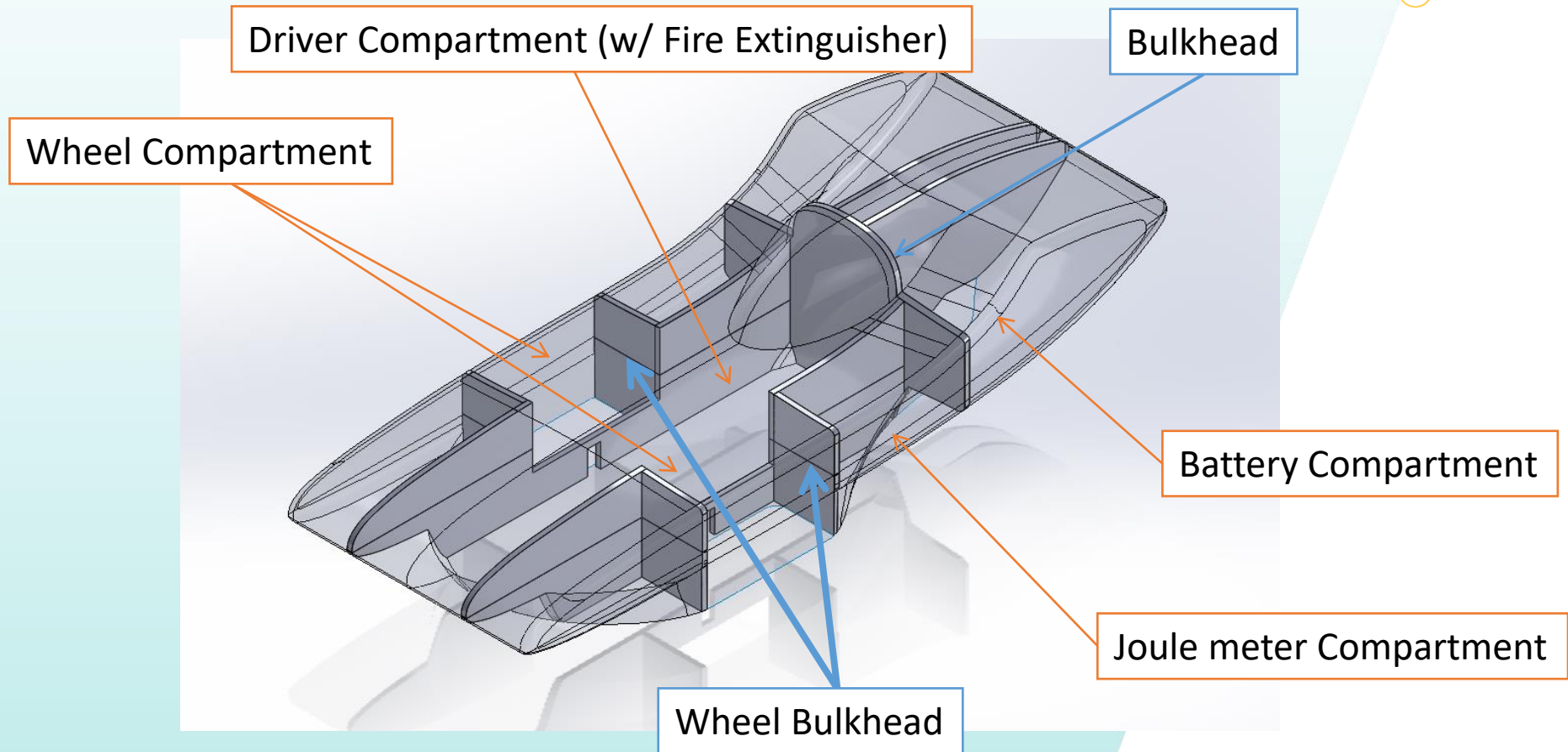

Dimension	Limits
Max. Height	1300mm
Max. Width	1300mm
Max. Length	3500mm
Track width	At least 1000mm(front axle); 800mm (rear axle) if applicable
Wheelbase	>1200mm
Ground clearance	>100mm
Max. vehicle weight (without driver)	225 kg

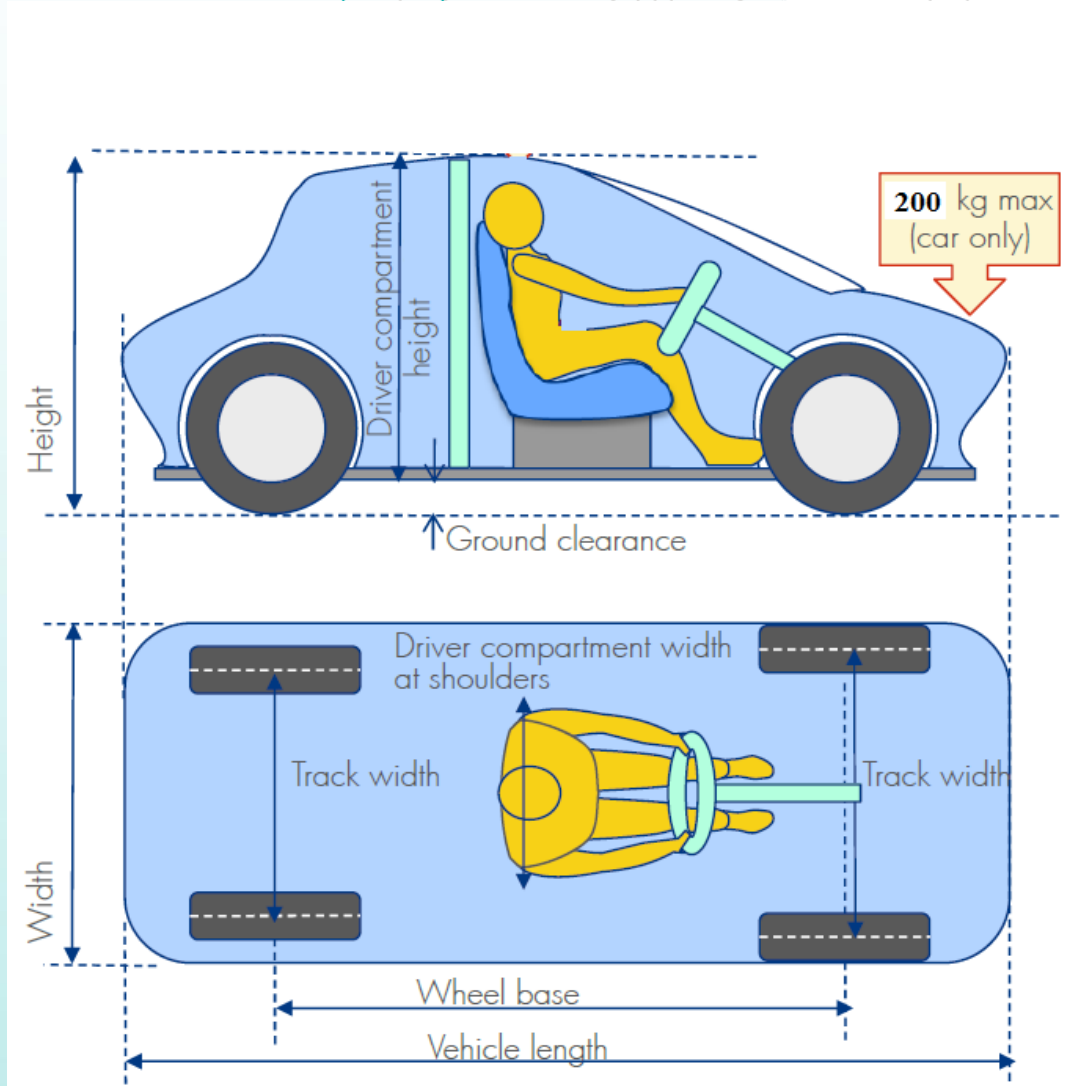

## 車架穩定性

- Chassis / Monocoque
  - Must be solid
  - Wide and long enough to protect driver
- Roll bar
  - >50mm above helmet
  - extend beyond shoulders
  - withstand 70kgf

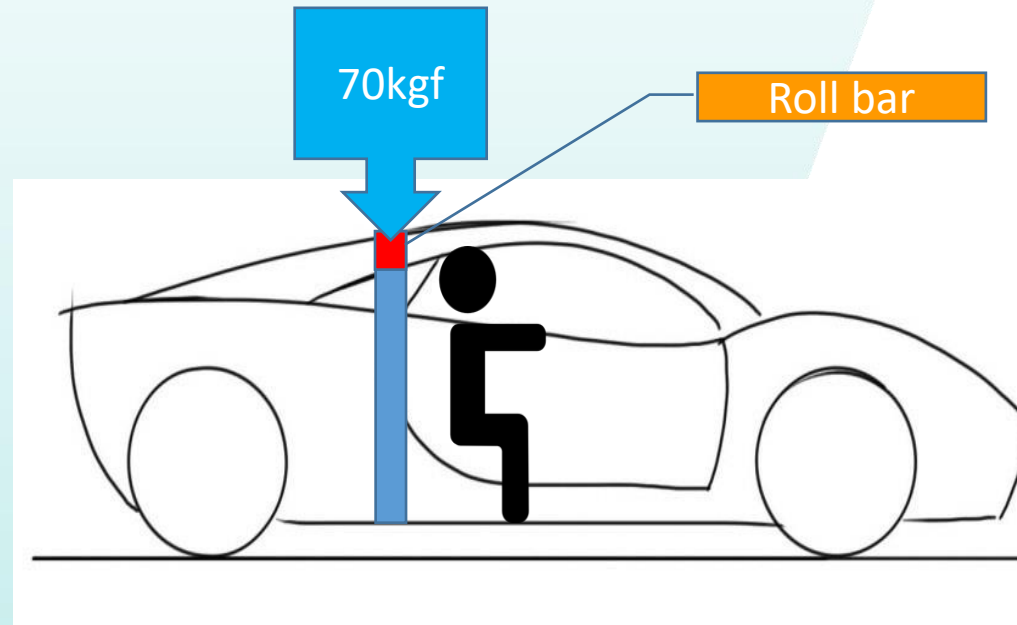

## 煞車系統 Braking system

# 煞車系統

- 制動器是一種透過吸收運動系統的能量來抑制運動的機械裝置。
- 它用於減慢或停止移動的車輛、車輪、車軸，或防止其運動，通常透過摩擦來實現

## 煞車系統 Braking system

2

2個獨立的煞車系統  
Independent  
Braking  
System

主要煞車系統  
Primary Braking

停車煞車系統  
Parking Braking

即使其中一個系統失靈，亦能夠煞停車輛！

Ensure the car can **STOP** moving!  
Even one of them **FAIL!**

## 煞車系統 Braking system

### 煞車 Brake

- 2 Independent system
- 4 Wheels  
(Front Left, Right Wheels, and Rear Left , Right Wheels)
- Control : Pedal / Brake lever
- Disc / Drum braking
- Hydraulic /Mechanical method

# 煞車系統 Braking system

## 碟式/鼓式 煞車器 Disc/Drum Brake

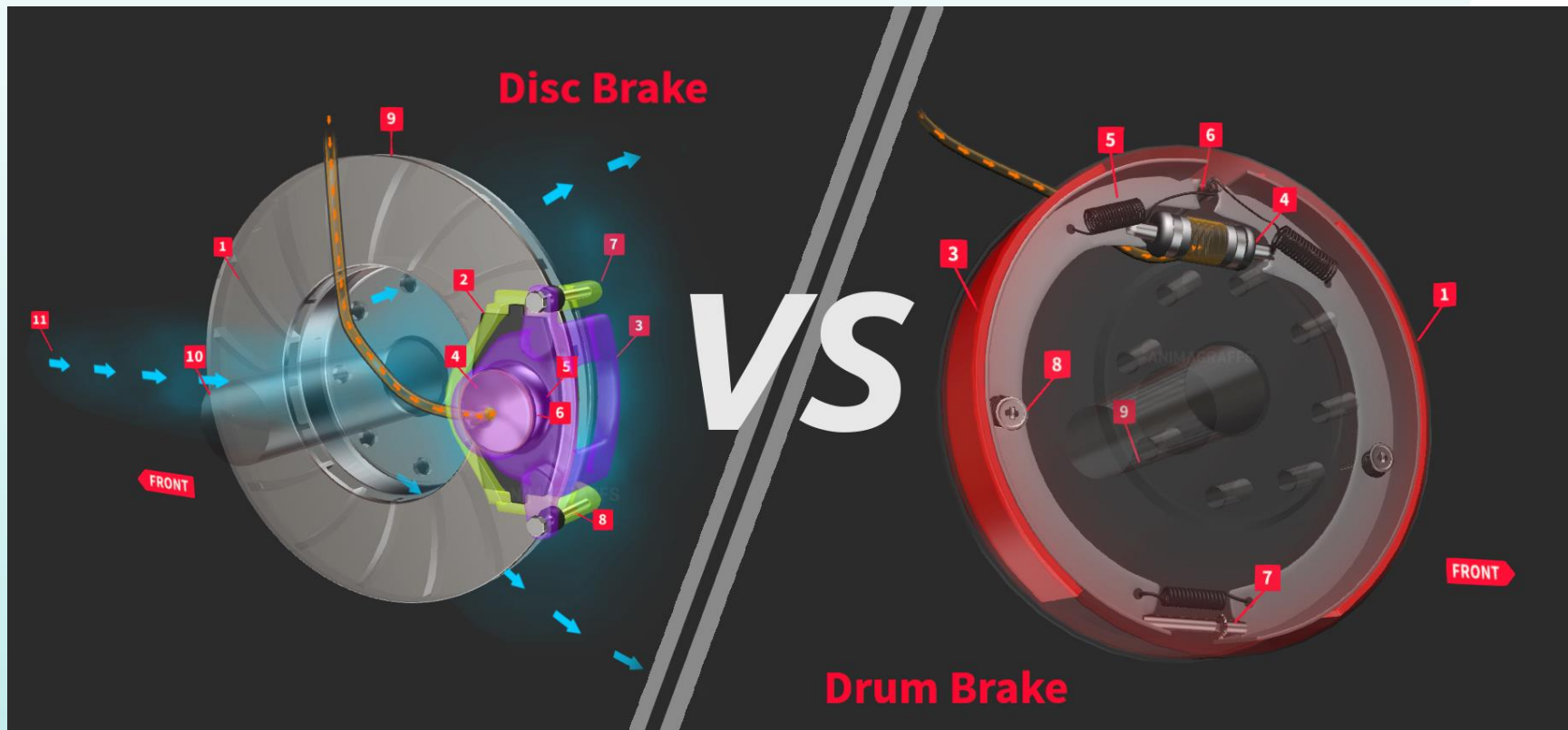



# 煞車系統 Braking system

## 鼓式煞車器 Drum braking

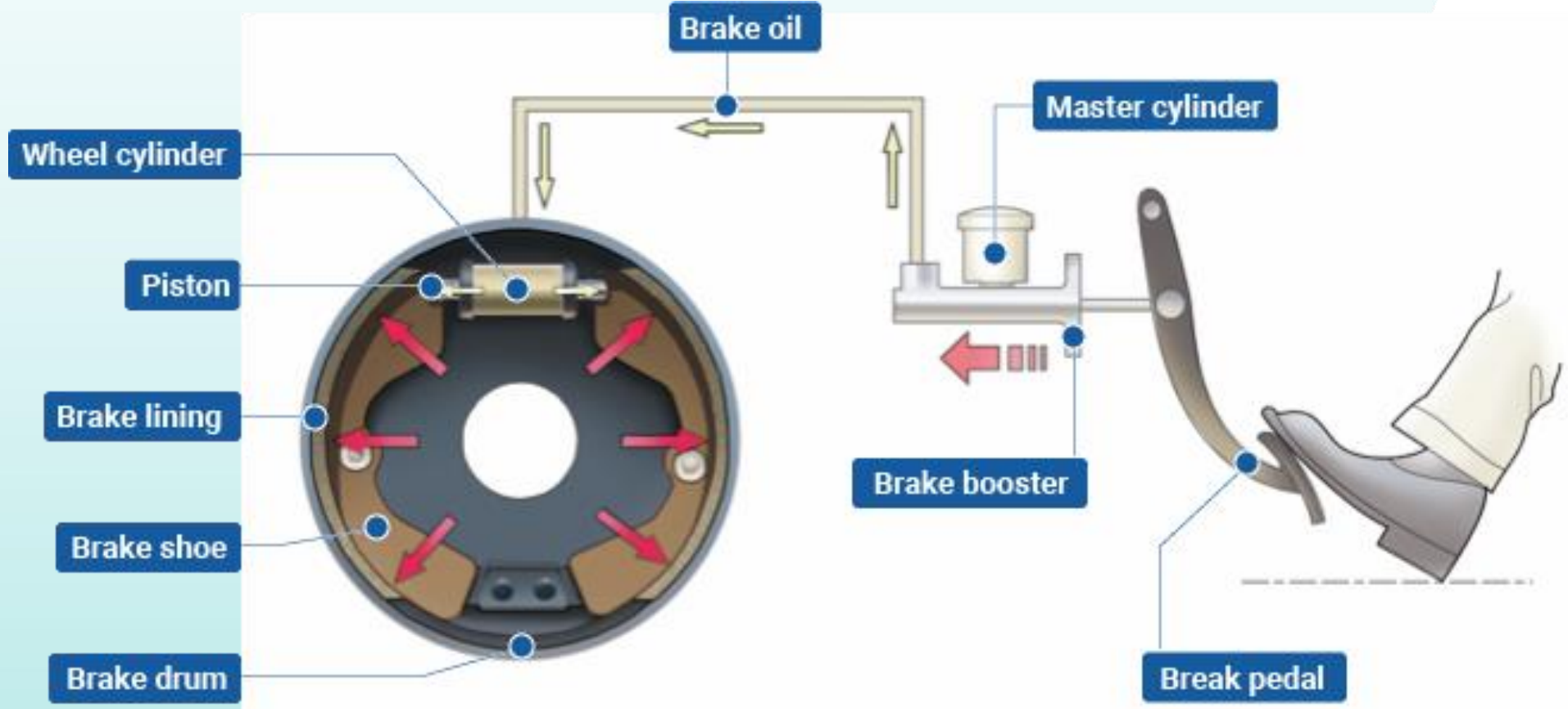



# 煞車系統 Braking system

## 碟式 煞車器 Disc Brake

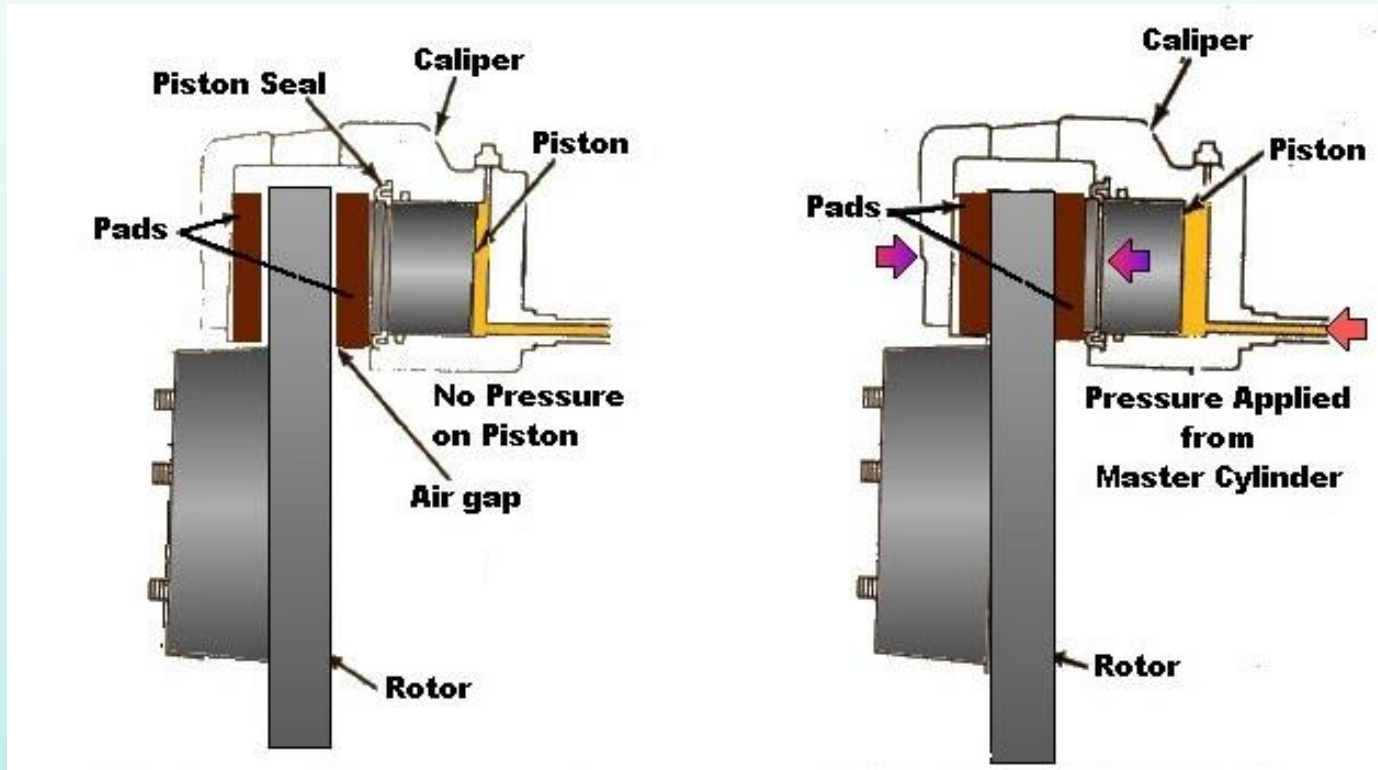

# 煞車系統 Braking system

## 油壓 Hydraulic method

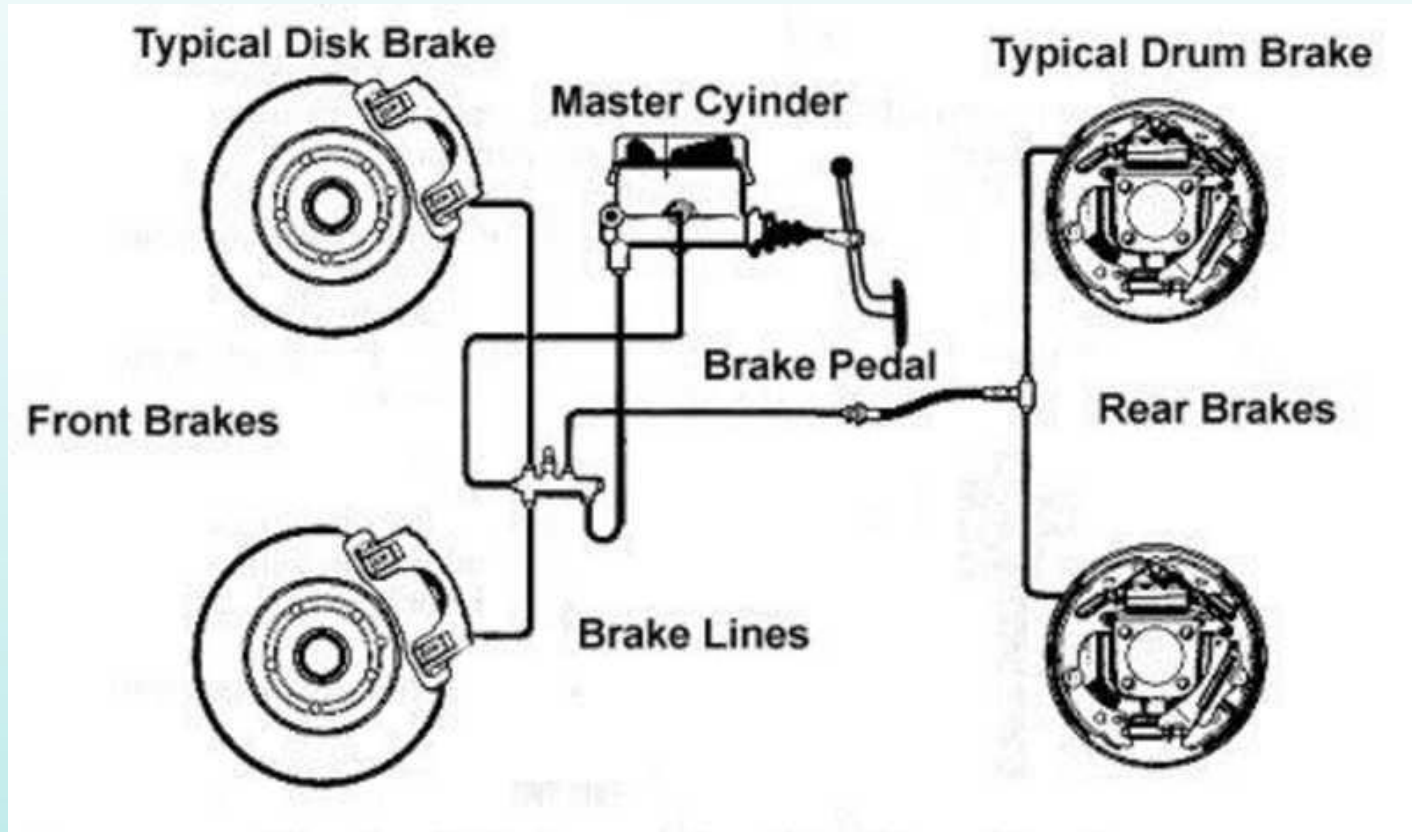

## 煞車系統 Braking system

### Mechanical Method 剎車拉線 (Cable Braking)



# 煞車系統 Braking system

Caution: Each system must NOT act only one side of wheels

Wrong connection

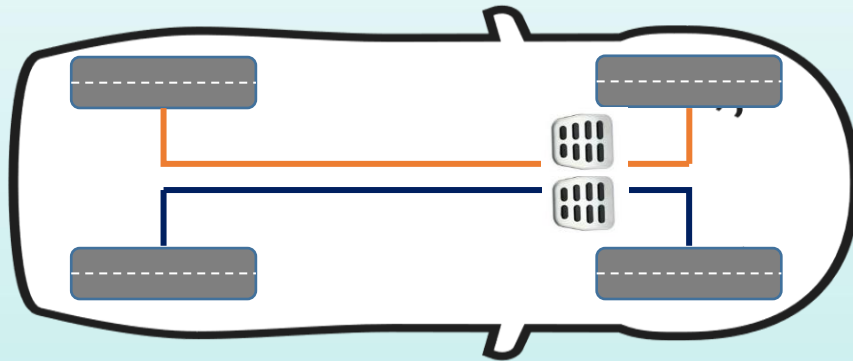

# 煞車系統 Braking system

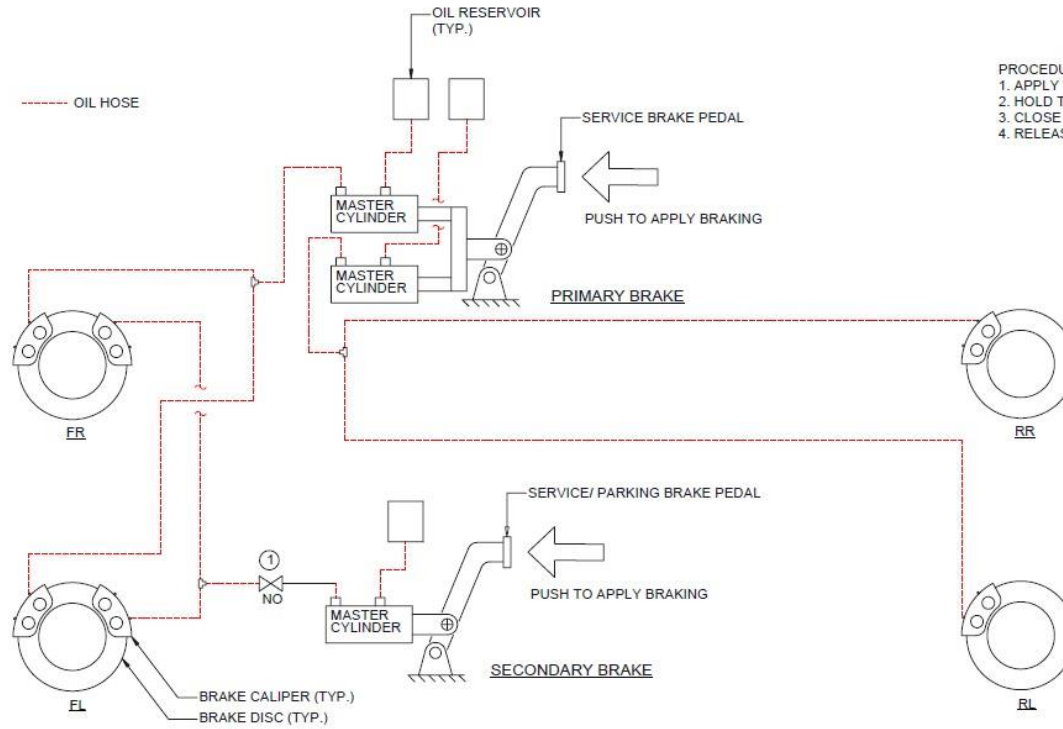

- PROCEDURE FOR USING PARKING BRAKE:
1. APPLY THE SECONDARY BRAKE.
  2. HOLD THE FOOT PEDAL.
  3. CLOSE THE NORMALLY OPENED VALVE 1.
  4. RELEASE THE FOOT PEDAL.

SOPHIE VI BRAKING SYSTEM DESIGN

## 轉向系統 Steering system

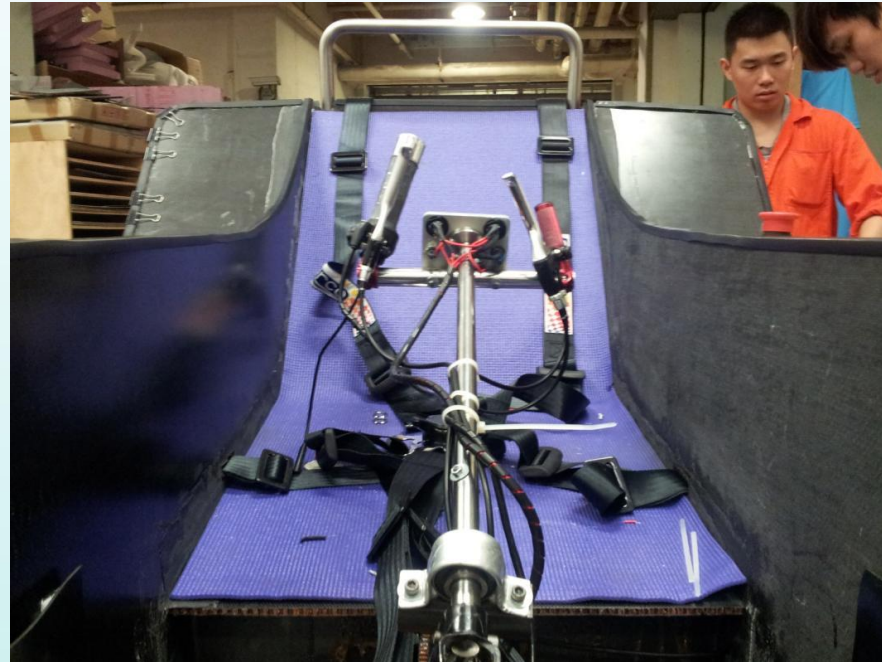

The function of a steering system is to convert the rotary movement of the steering wheel in driver's hand into the angular turn of the front wheels on road.



# 轉向系統 Steering system

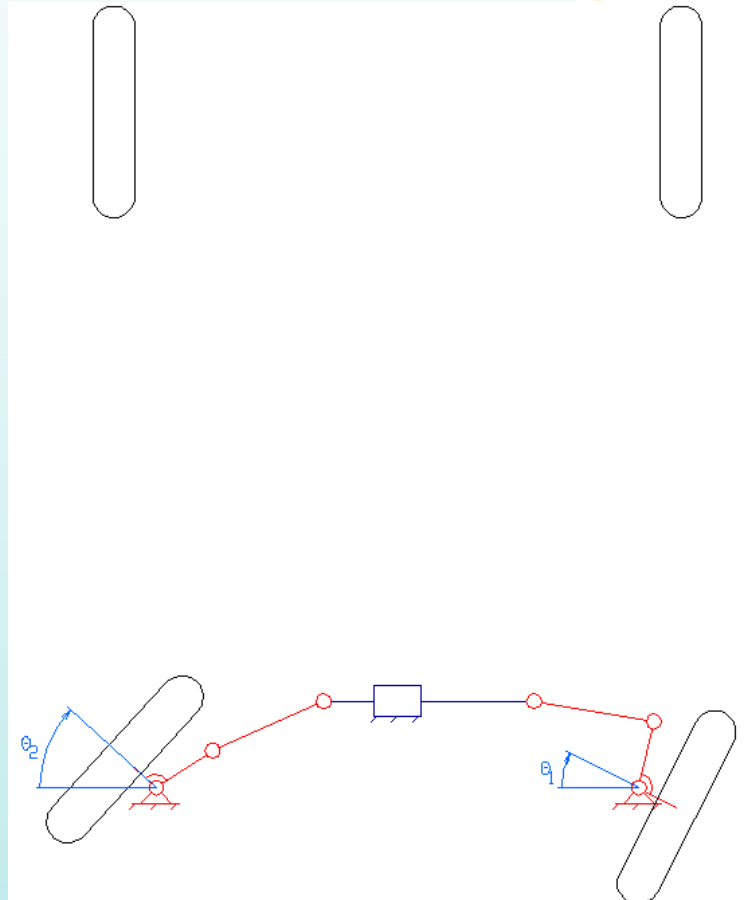
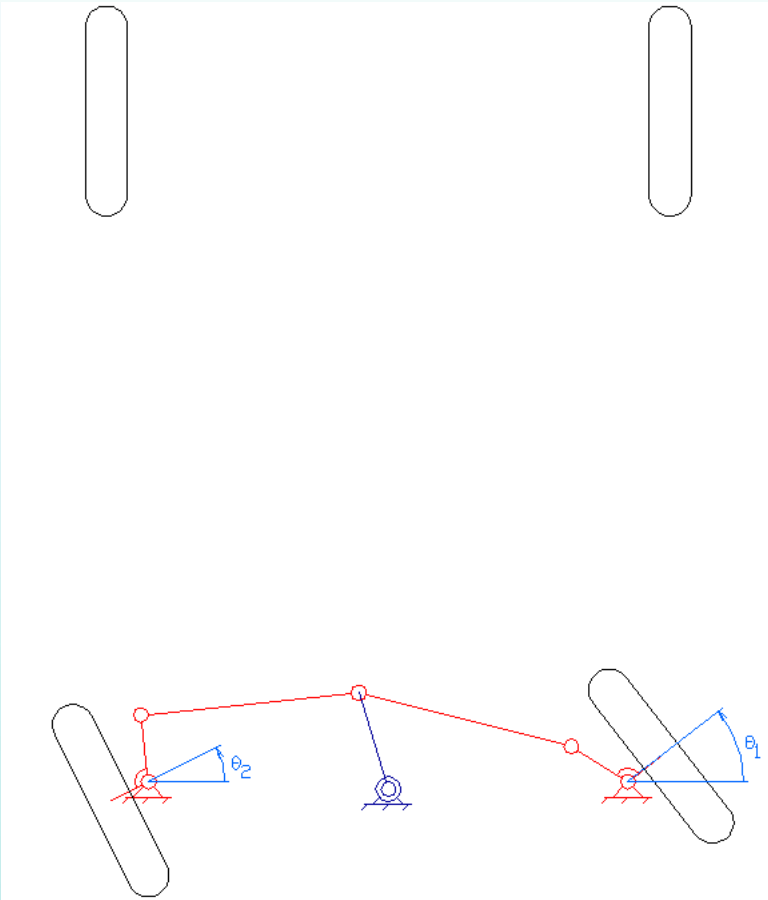

# 轉向系統 Steering system



## 轉向系統 Steering system

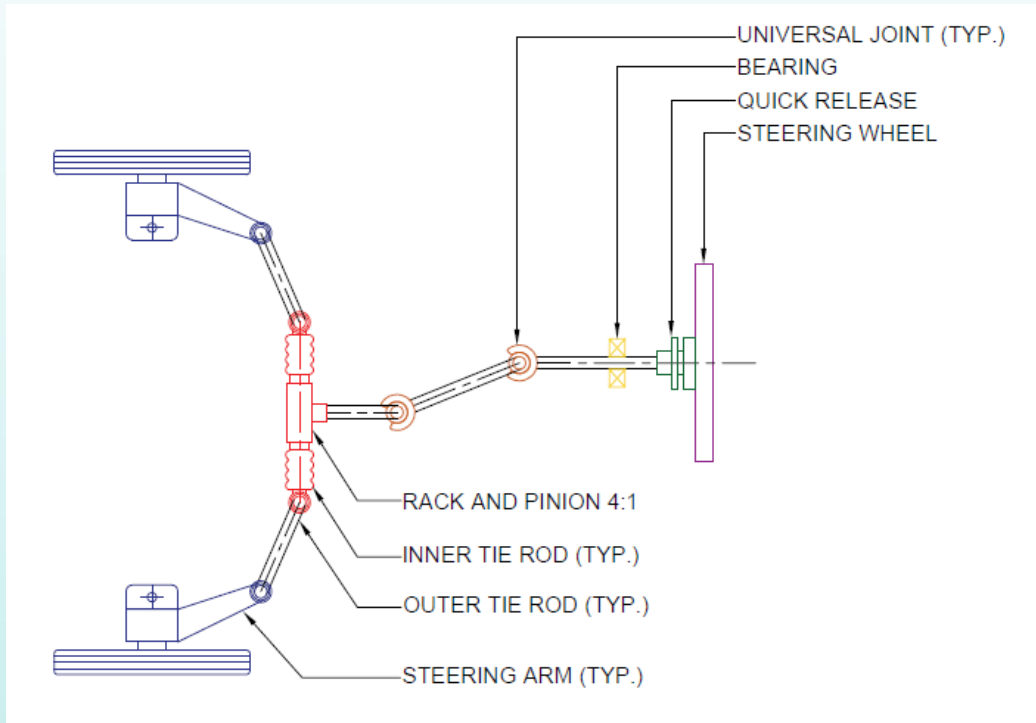

How many deg of steering wheel need to turn?

From Catalogue:

Rack and pinion 6.4:1, 360deg->119.68mm

From Sophie V dimension:

$$R_{sa} = 250\text{mm}$$

$$\delta_s = 20 \text{ deg}$$

$$\tan \delta_s = \frac{\text{travel}}{R_s}$$

Ans: 273 deg



# 轉向系統 Steering system

$$\tan b = \frac{H}{R - \frac{W}{2}}$$

$$\tan a = \frac{H}{R + \frac{W}{2}}$$

$$R + \frac{W}{2} = 8 \text{ meters}$$

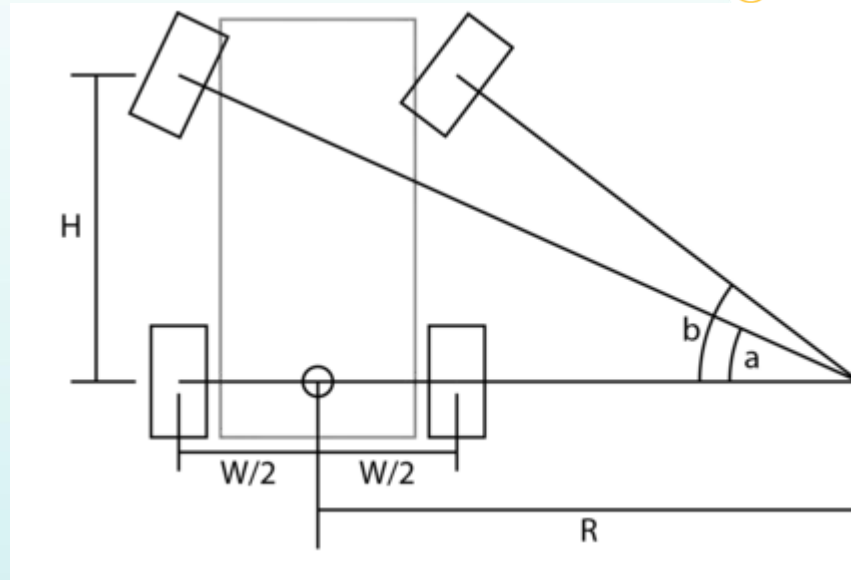

Example:

Car	H(m)	W(m)	Angle a (deg)	Angle b (deg)
Sophie V	2.35	1.4	16.37	19.60
Sophie VI	2.75	1.4	18.97	22.62

# 懸掛系統 Suspension System

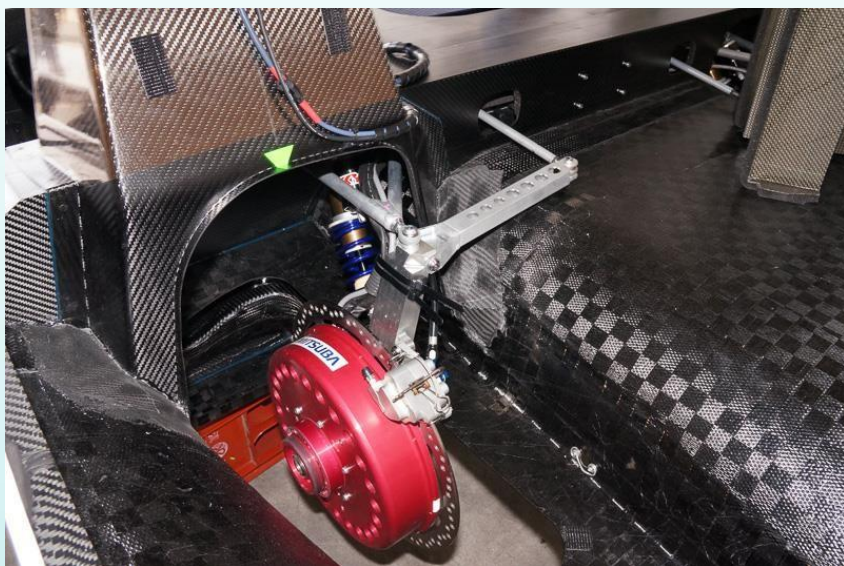

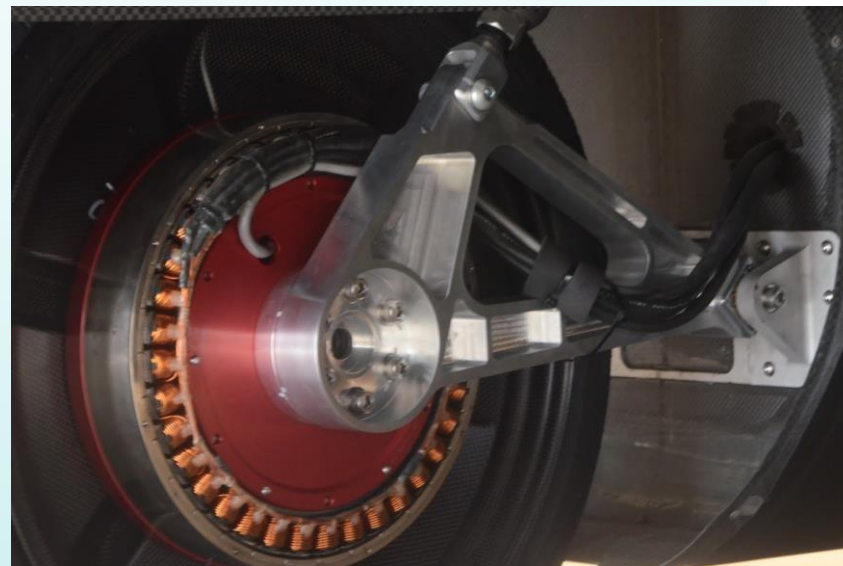

帶轉向的拖曳臂  
(Tailing Arm with steering)



拖曳臂  
(Tailing Arm)

# 四輪定位 Wheel Alignments

 Wear Indicator	 Overinflation	 Underinflation	 Negative Camber	 Positive Camber
 Camber Wear	 Feathered Wear (Excessive Toe In or Out)	 Spotty / Chopped Wear (Multiproblem)	 Toe In	 Toe Out
 Diagonal Wear / Heel & Toe Wear	 Local Wear	 Negative Caster	 Positive Caster	

## 四輪定位 Wheel Alignments

外傾角(Camber)

Target Value:

- 0 ° Front
- 0 ° Rear

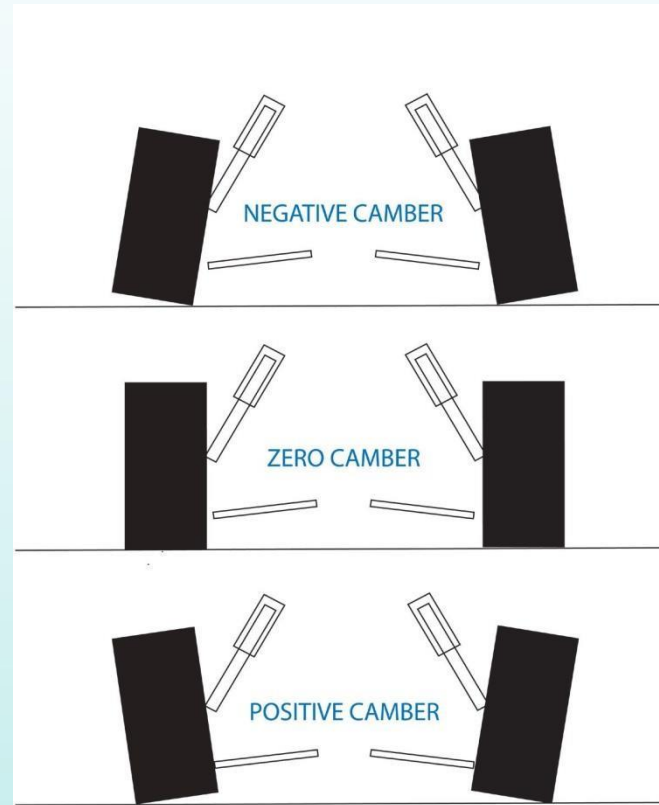

# 四輪定位 Wheel Alignments

内八字/外八字 Toe in/Out

Target Value:

- Less than 0.25° Front Toe In
- 0mm Rear Toe

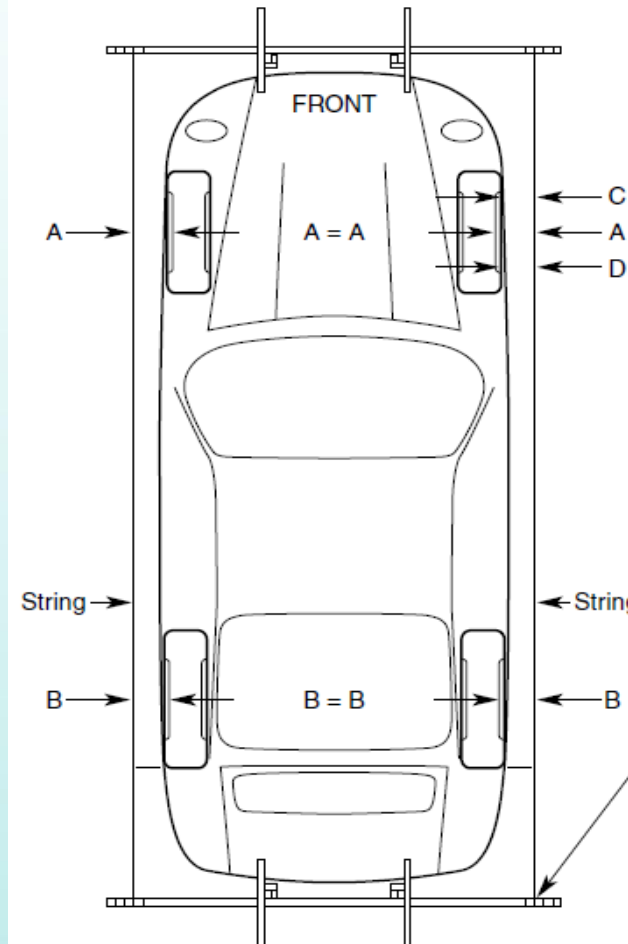

**Toe-in:**  
The measurement is **longer** on the leading edge of the wheel than the trailing edge of the wheel.  
**Example:** Measurement C is **longer** than measurement D.

**Toe-out:**  
The measurement is **shorter** on the leading edge of the wheel than the trailing edge of the wheel.  
**Example:** Measurement C is **shorter** than measurement D.

**Note:**  
This is true for both the front and rear axles.

**Note:**  
By using the same groove in the bar both front and rear, the strings are now parallel to each other. Measurement A and B will most likely not be the same.

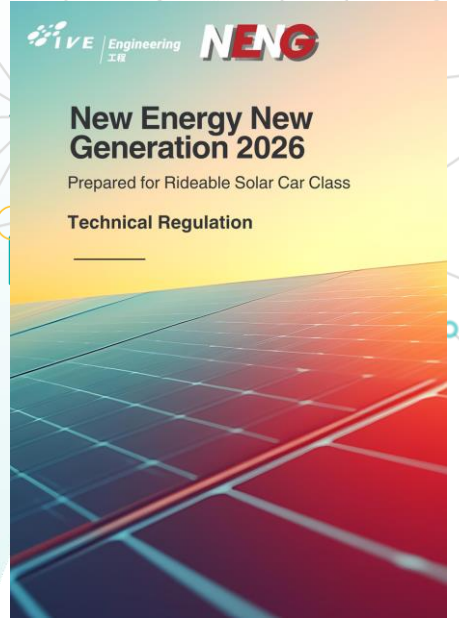

## Wheel Alignments

Refer to NENG  
Rideable Solar  
Car Regulation  
2026

- Ventilation?
- Doors?
- Visibility? Rear vision?
- Lighting? e.g. head light, indicator light, rear light, brake light, etc.
- Horn
- Etc.

小休



能源應用

輸入功率  
Input Power

太陽能板→電池→馬達

輸出功率  
Output Power

滾動阻力  
空氣阻力  
加速

# 主要部件

# 太陽能車

## 使用太陽能進行車載充電

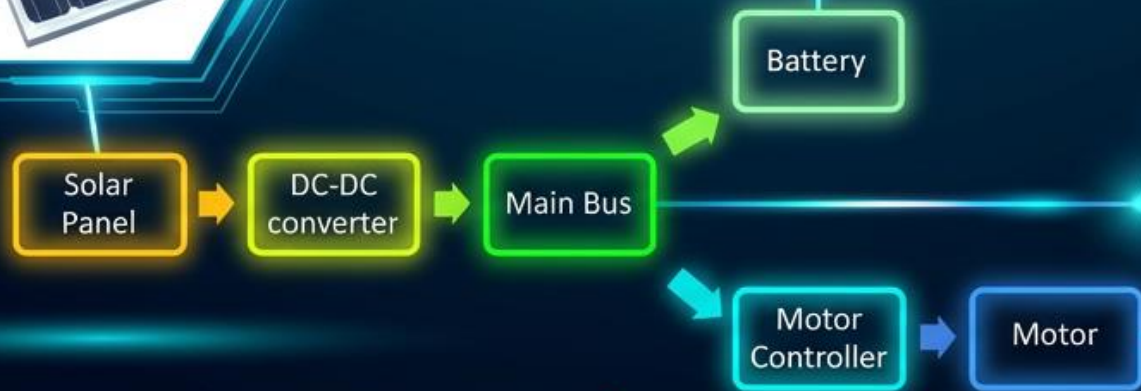

## 電能

電能(**Electrical Energy**) 是電荷 (electrical charge) 的存在和流動，通常儲存在電池中，並通常透過電線以電子形式傳遞。

例如：電能儲存在車電池中



# 電能

靜電 (Static)



電磁 (Electromagnetic)

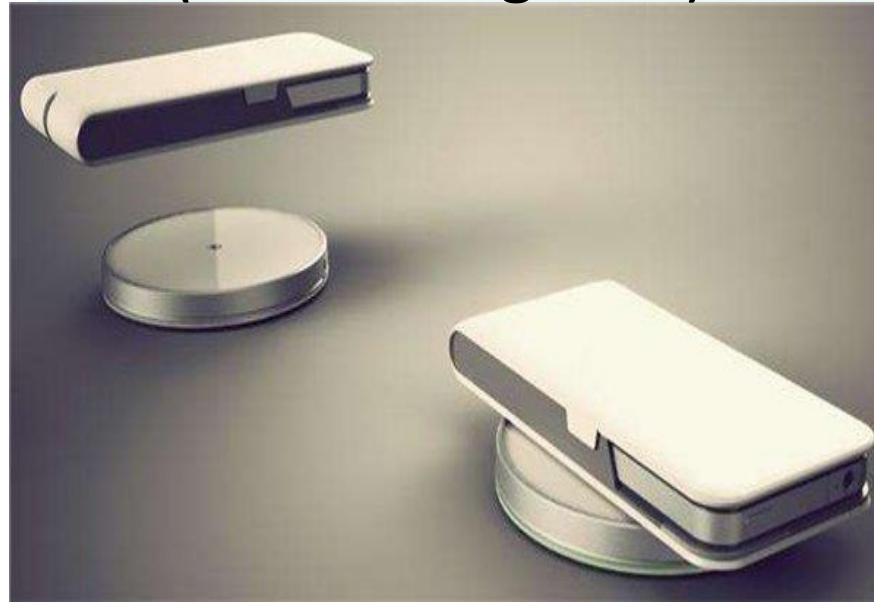

電化學反應  
(Electrochemical  
reaction)

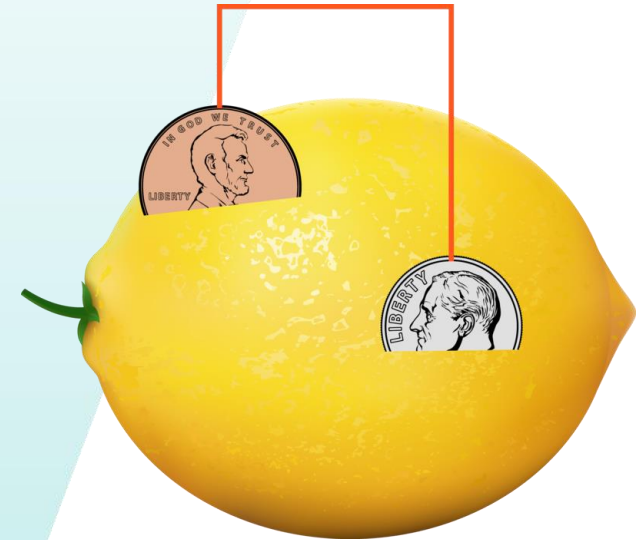

## 基礎電學

電力擁有自己的單位。在電氣系統中，最基本的三個單位是：

- 1) 電壓（V）是衡量電流的「推力」。電壓越高，推動電流通過電線的力量就越大。
- 2) 電流（I）是單位時間內通過一個點的電荷量的度量。
- 3) 瓦特（W）表示完成工作或使用能量的速率。

$$V \times I = W$$

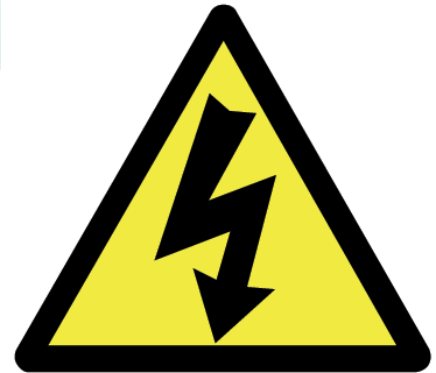

# 電能

## 水管類比 (Water Pipe Analogy)

想像一下水管系統，其中水的流動可以類比為電力在電路中的流動。

**Electricity: Not-Visible**  
**Water: Visible**

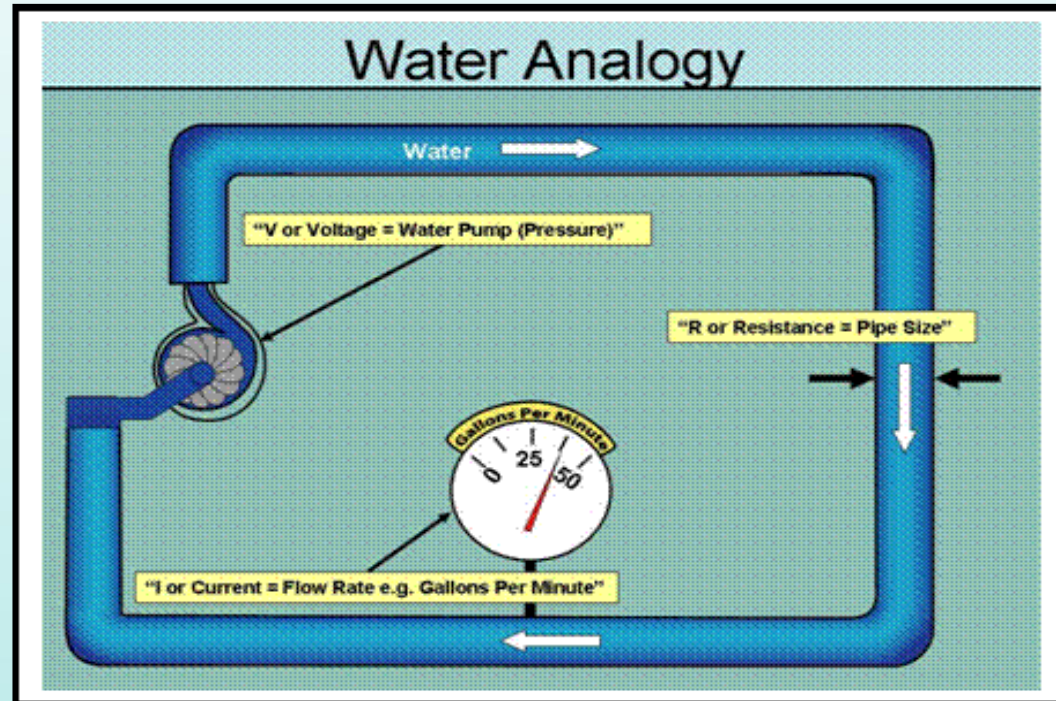



電能

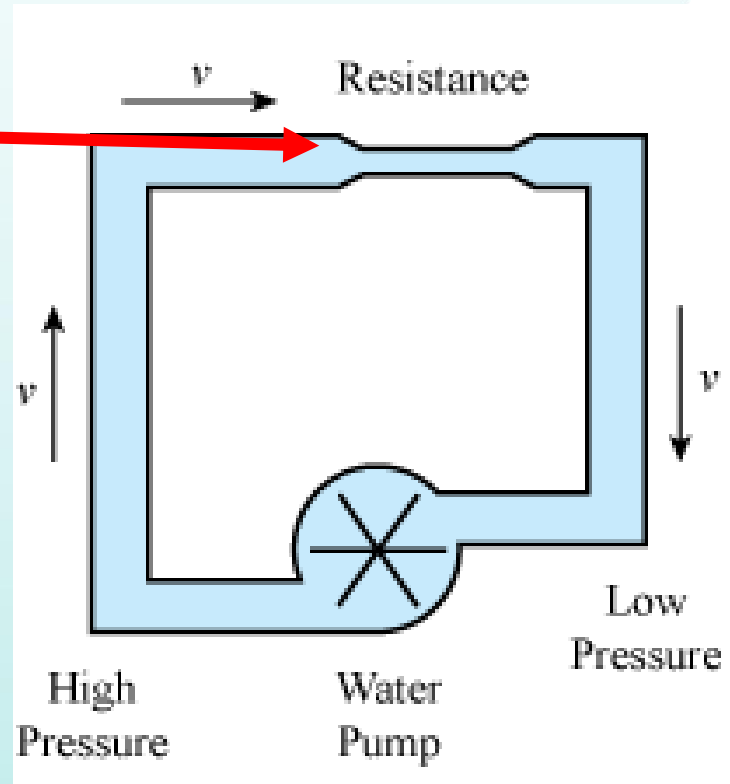
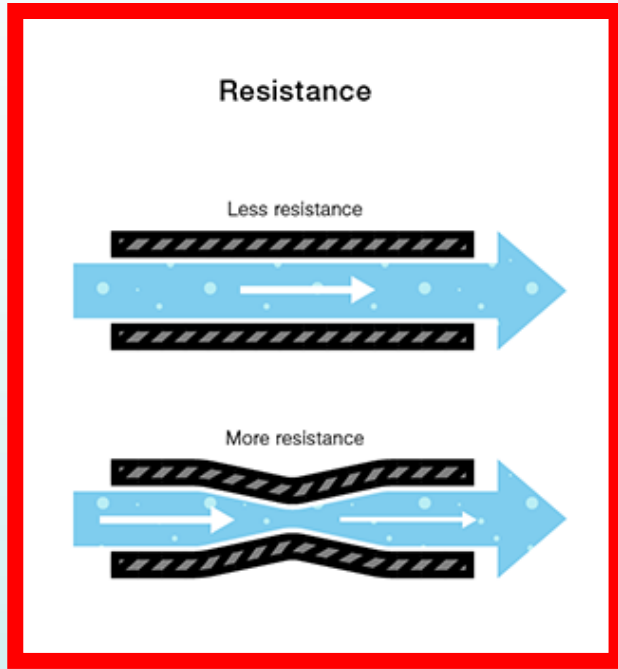

## Ohm's Law

Resistance is the opposition that a substance offers to the flow of electric current.

Quantities	Abbreviations	Units	Label
Voltage	V or E	Volts	V
Current	I	Amperes	A
Resistance	R	Ohms	$\Omega$

$$V=IR$$

$$I=V/R$$

$$R=V/I$$

電能

輸入功率 Input power

a) 太陽能

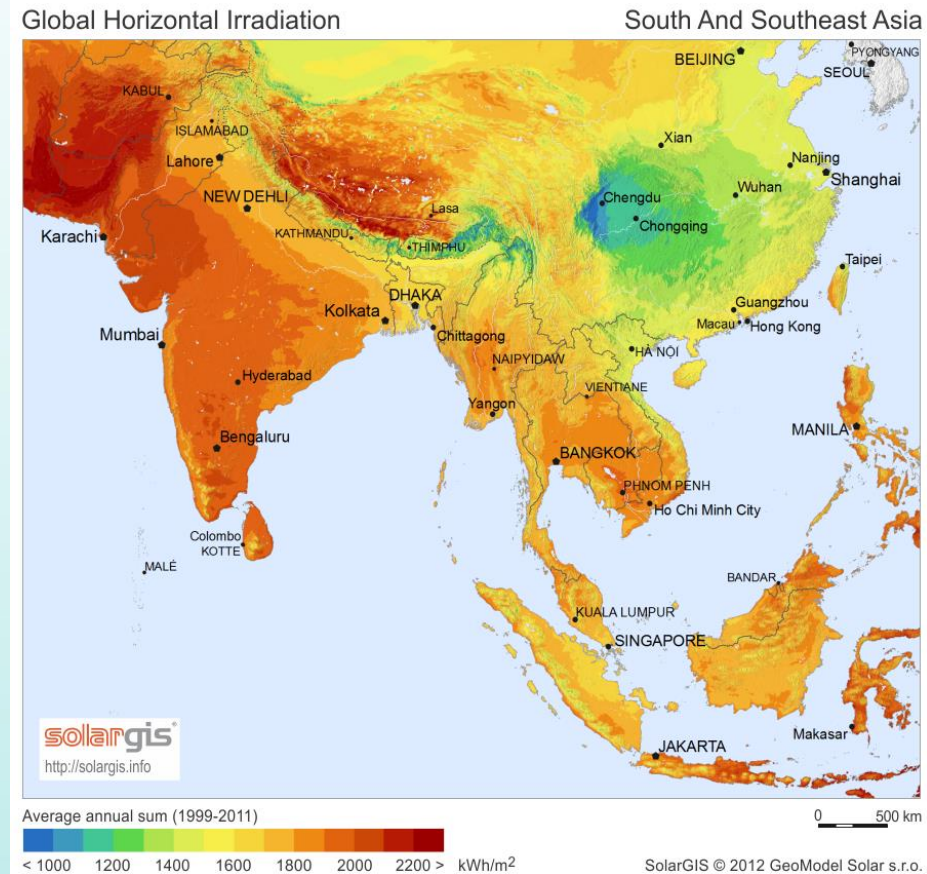



# 太陽能板應用

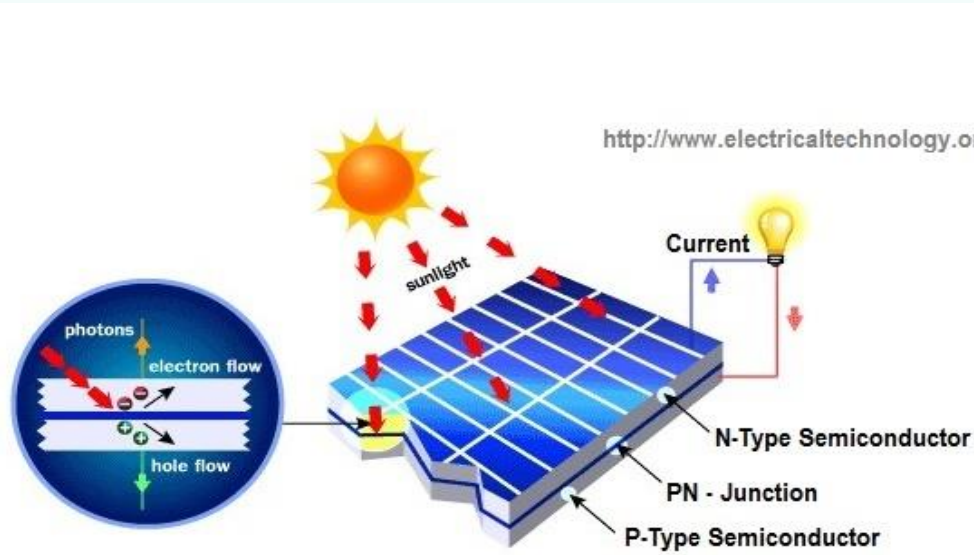

**Basic Operating Principle of a Solar Cell**

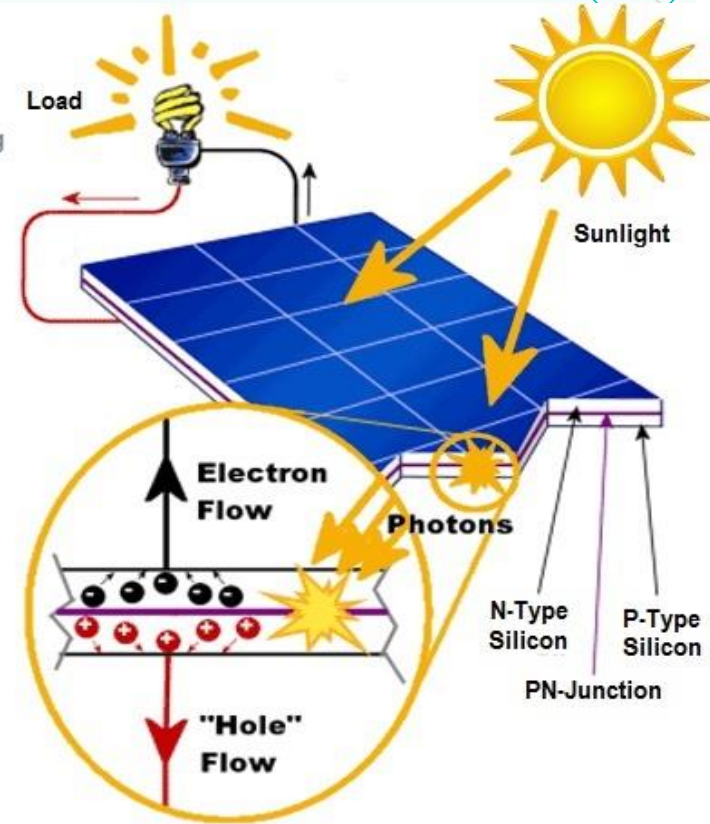



# 太陽能板

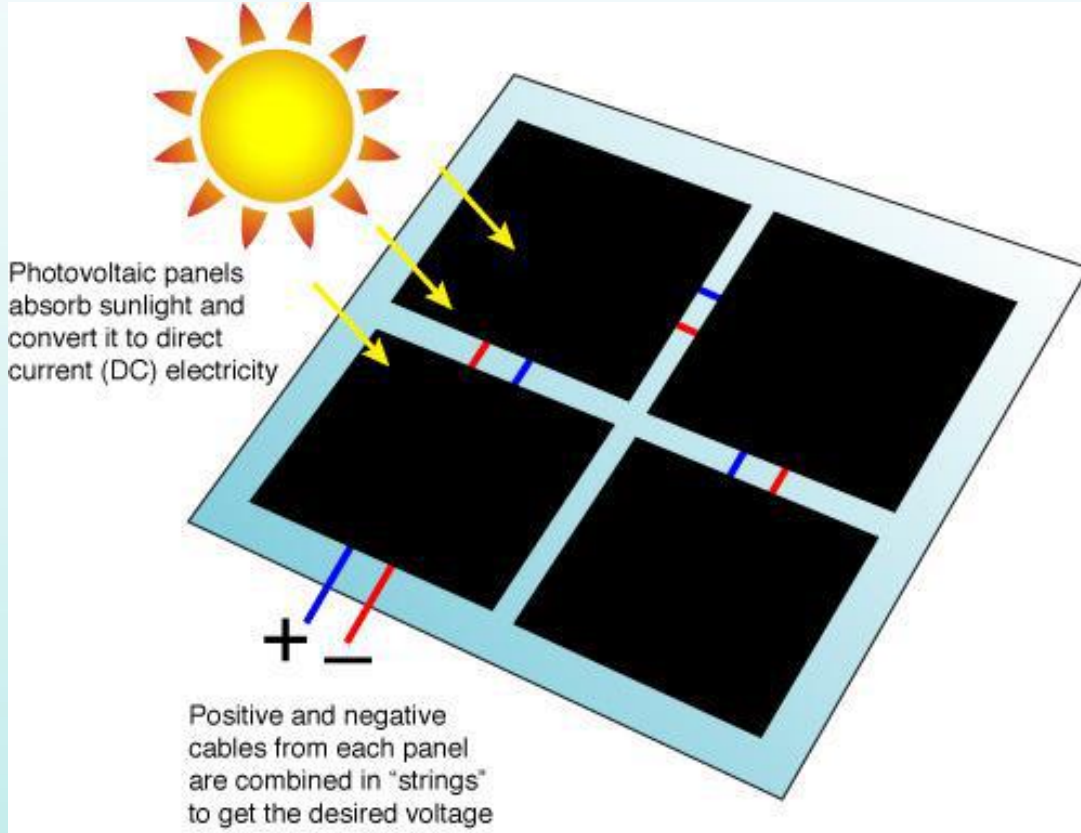

➤ 從太陽能板獲得最大功率輸出

- 向太陽傾斜 **Tilt towards sun**



電能

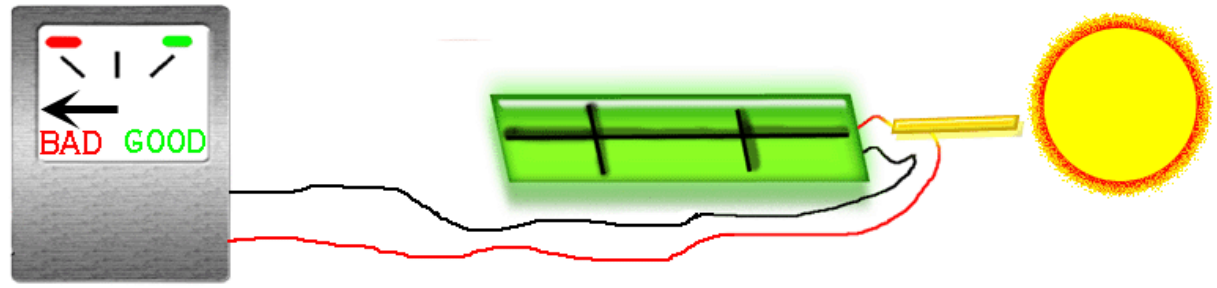
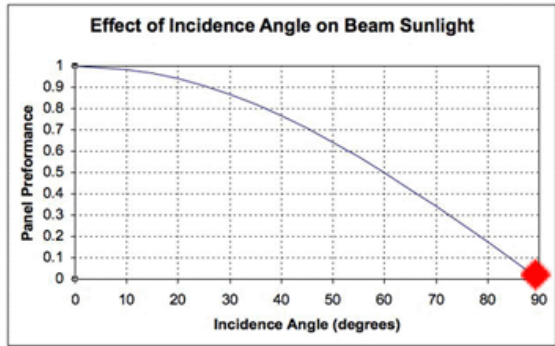



電能

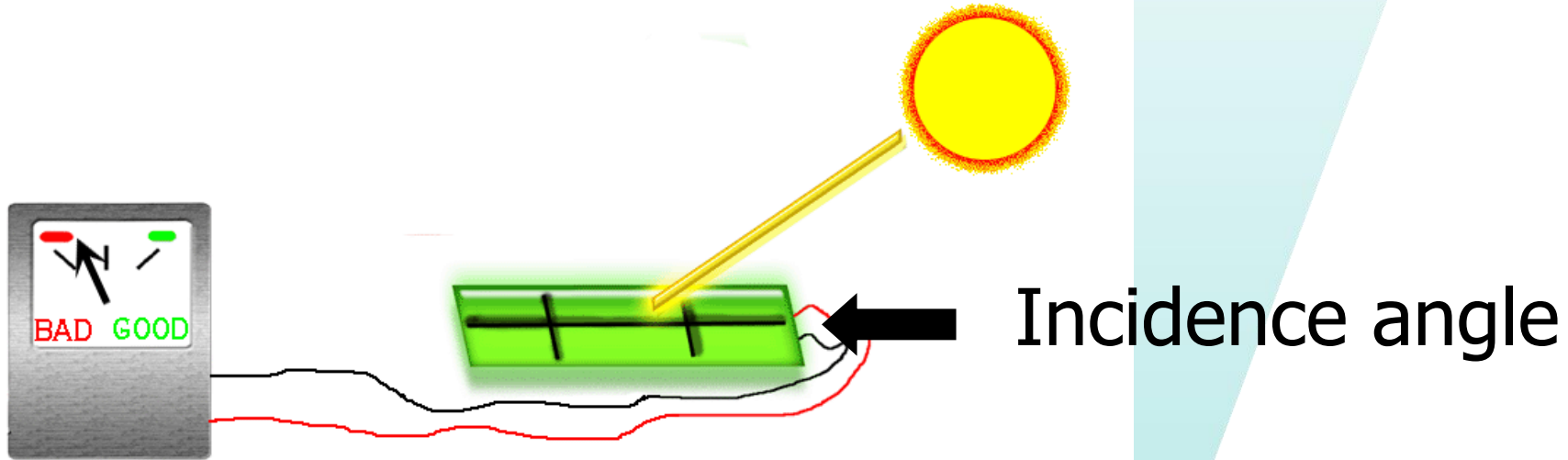
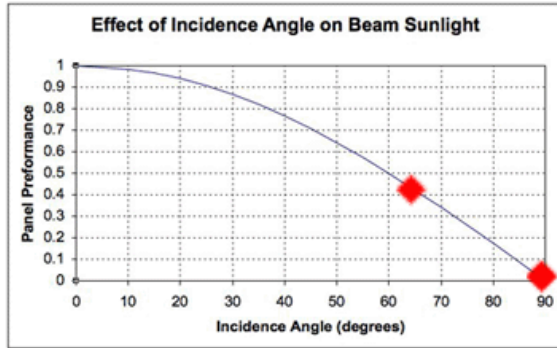

電能

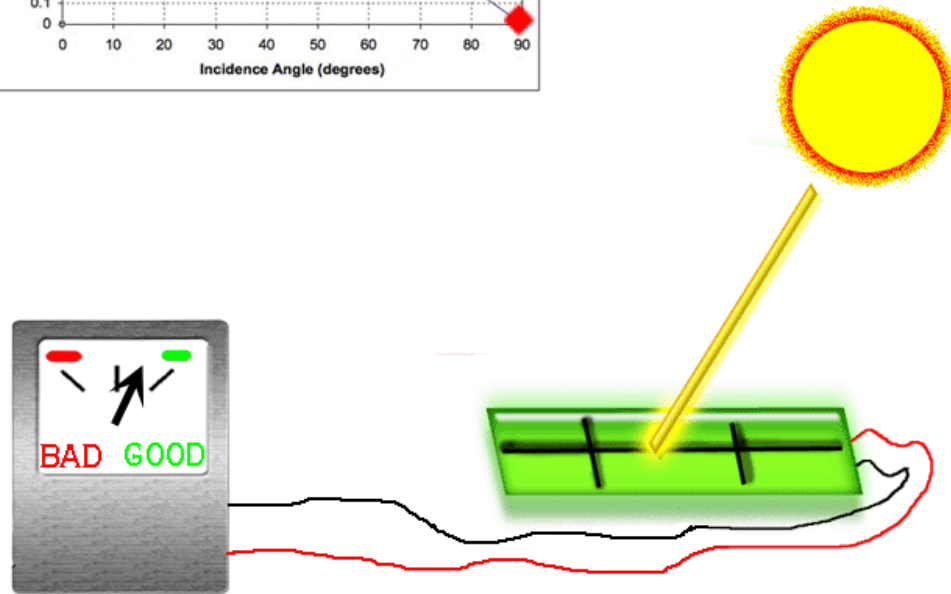
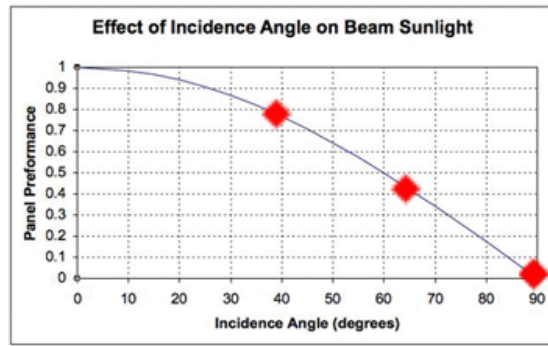

電能

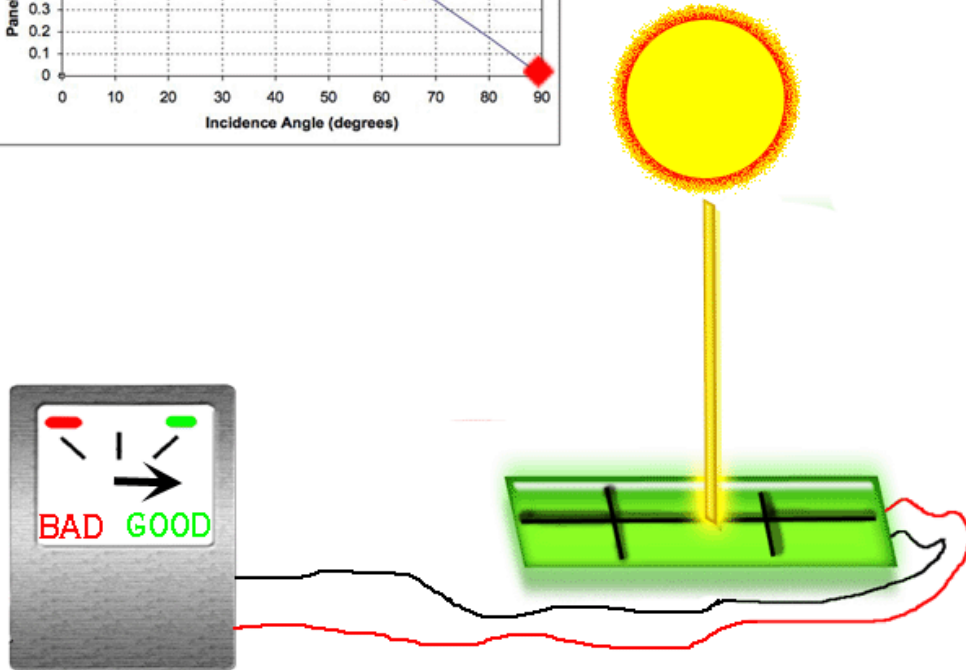
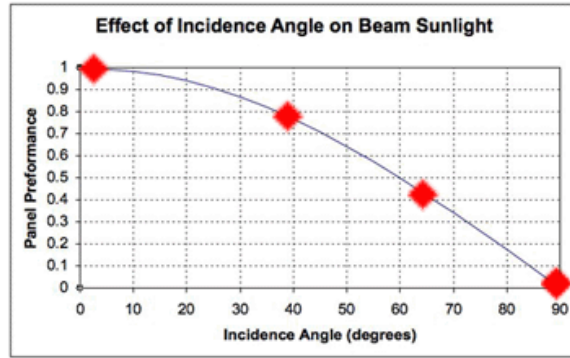



電能

# 太陽在哪裡？

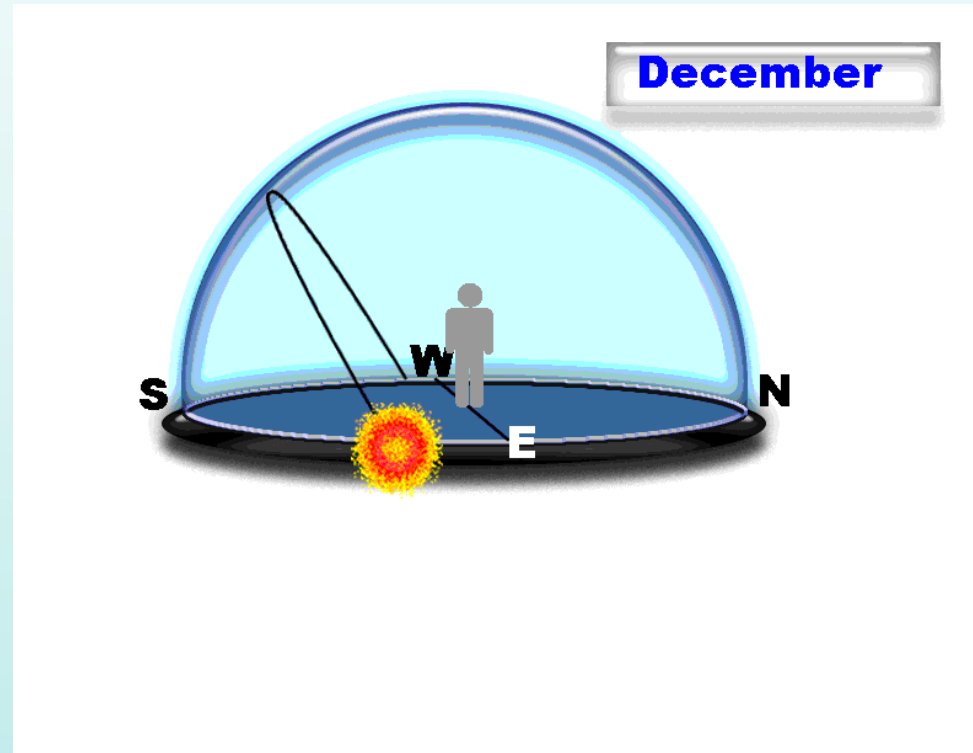

# 太陽在哪裡？

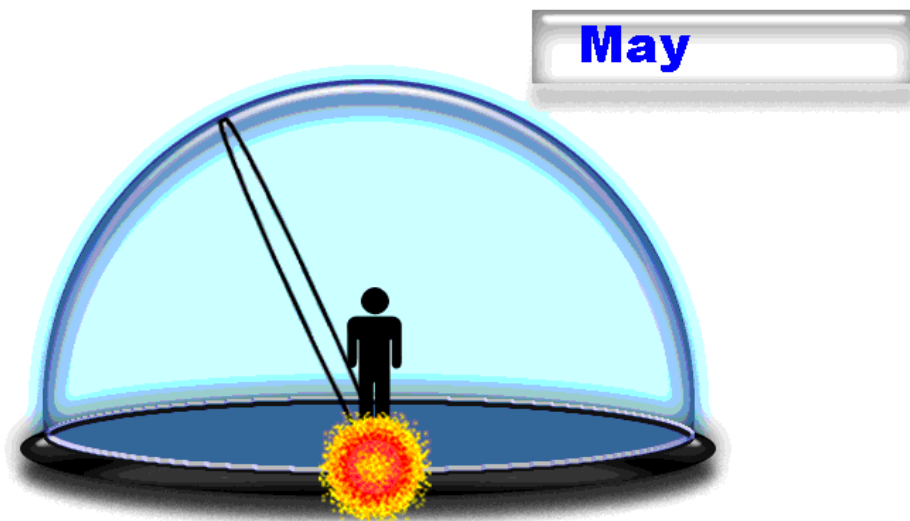

5月20日太陽將升到70度左右  
正午（下午 1 點）。

# 太陽能板連接

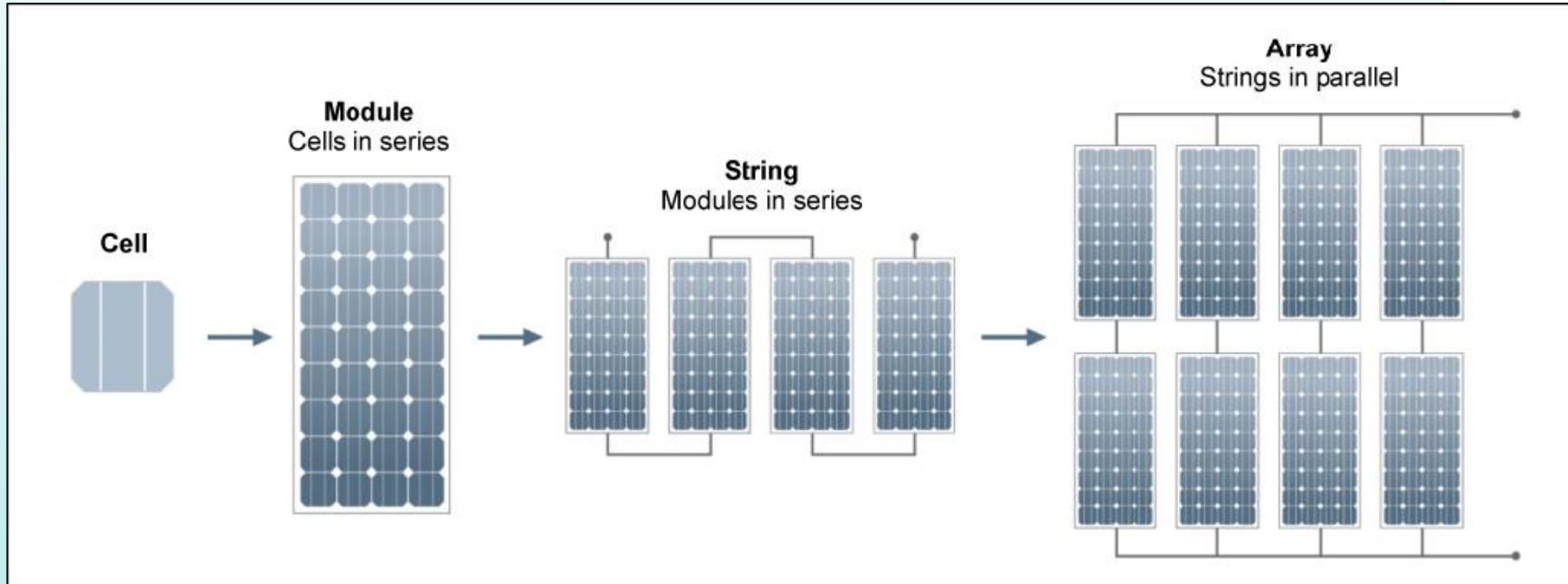

# 太陽能板V-I特性曲線

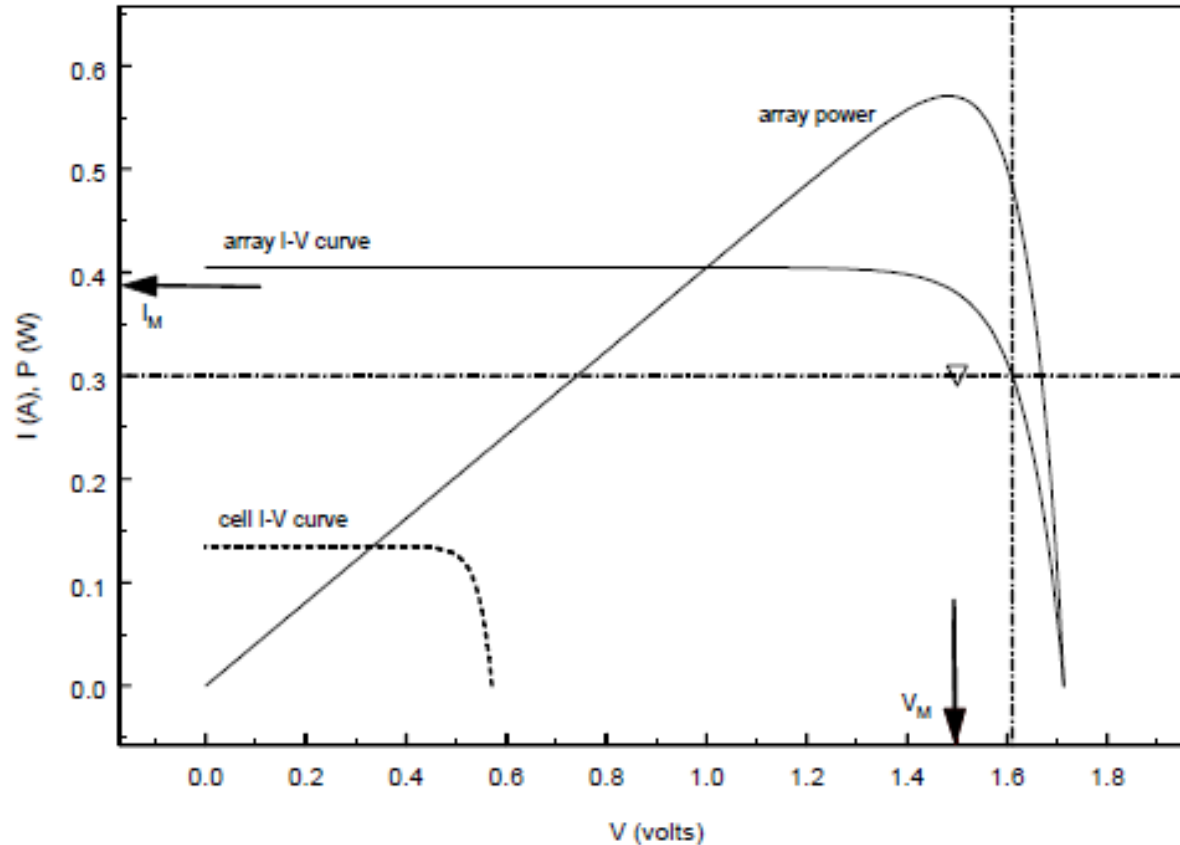

電能

例子

- 計算該太陽能板陣列的功率輸出。

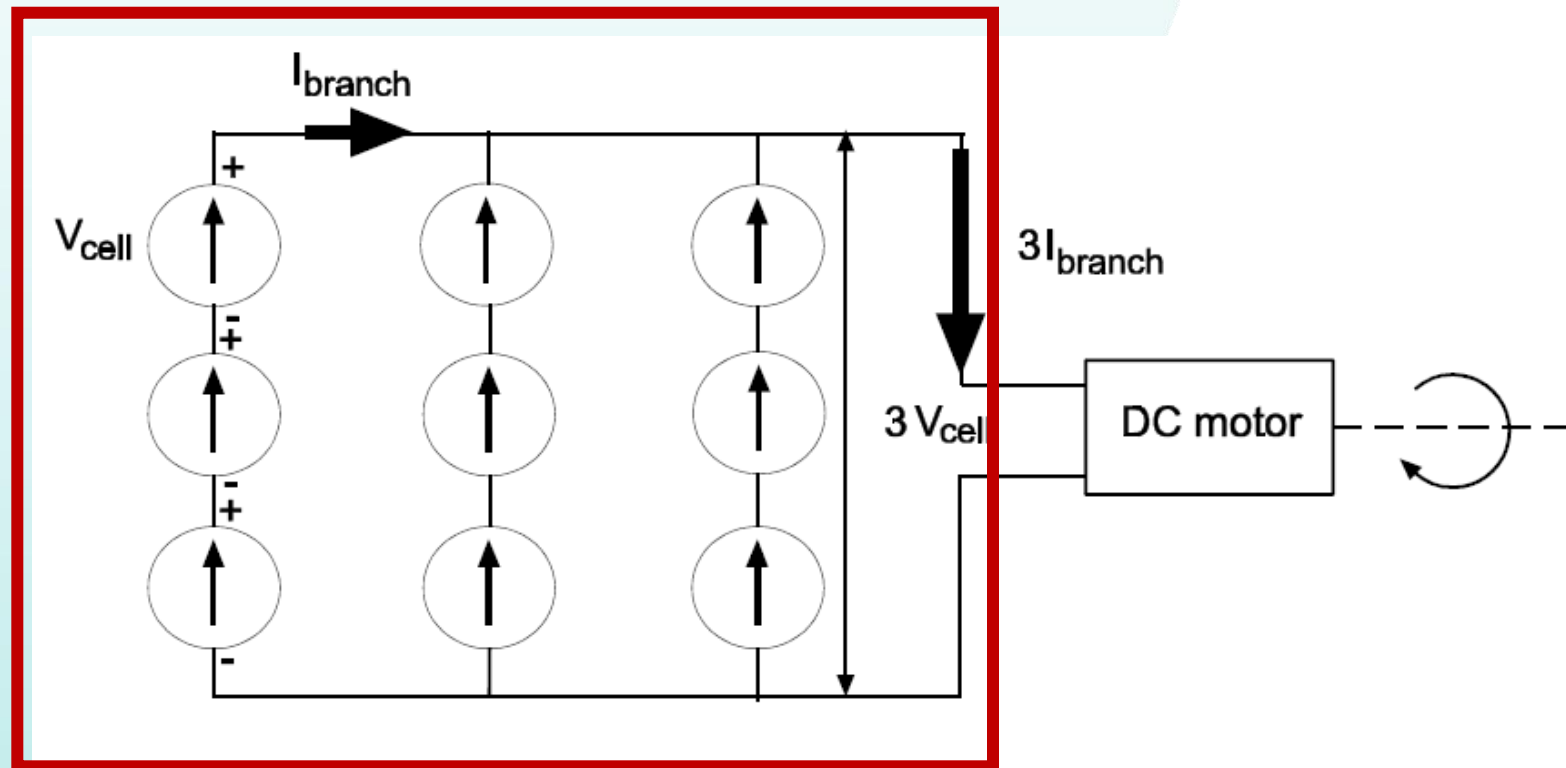

電能

**A-300 SOLAR CELL**  
MONO CRYSTALLINE SILICON

**Physical Characteristics**

Construction: All-back contact  
Dimensions: 125 mm x 125 mm - nominal  
Thickness: 270  $\mu\text{m} \pm 40 \mu\text{m}$

**ELECTRICAL CHARACTERISTICS OF TYPICAL CELL AT STANDARD TEST CONDITIONS (STC)**

STC is defined as: Irradiance of 1000W/m<sup>2</sup>, spectrum AM 1.5g and cell temperature of 25°C

Open Circuit Voltage: 0.670 V  
Short Circuit Current: 5.9 A  
Maximum Power Voltage: 0.560 V  
Maximum Power Current: 5.54 A  
Rated Power: 3.1 W  
Efficiency: Up to 21.5 %

**Temperature Coefficients**

Voltage: -1.9 mV / °C  
Power: -0.38 % / °C

**ATTRIBUTES**

- High efficiency reduces module assembly and system installation costs
- Uniform front appearance - no contact grid
- Back contact design simplifies circuit assembly
- Lower temperature coefficient improves energy delivery

**PACKAGING**

- Cells are packed in boxes of 1000 each; grouped in shrink-wrapped stacks of 50 with interleaving
- Twelve boxes are packed in a water-resistant "Master Carton" containing 12,000 cells suitable for air transportation

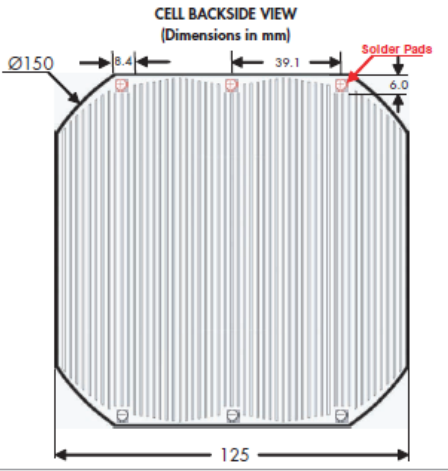
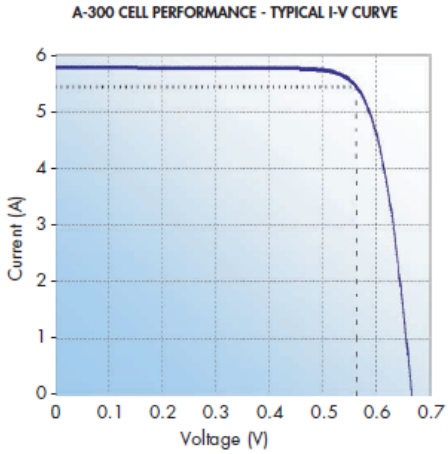

© March 2005 SunPower Corporation. All rights reserved. Specifications included in this datasheet are subject to change without notice.

Document: 70-0006 Rev04



電能

例子

太陽能板陣列的電壓:

➤ 1 series:

1 cell voltage:

= 0.5V

3 cell on 1 series:

= 3 x 0.5 V

=1.5 V

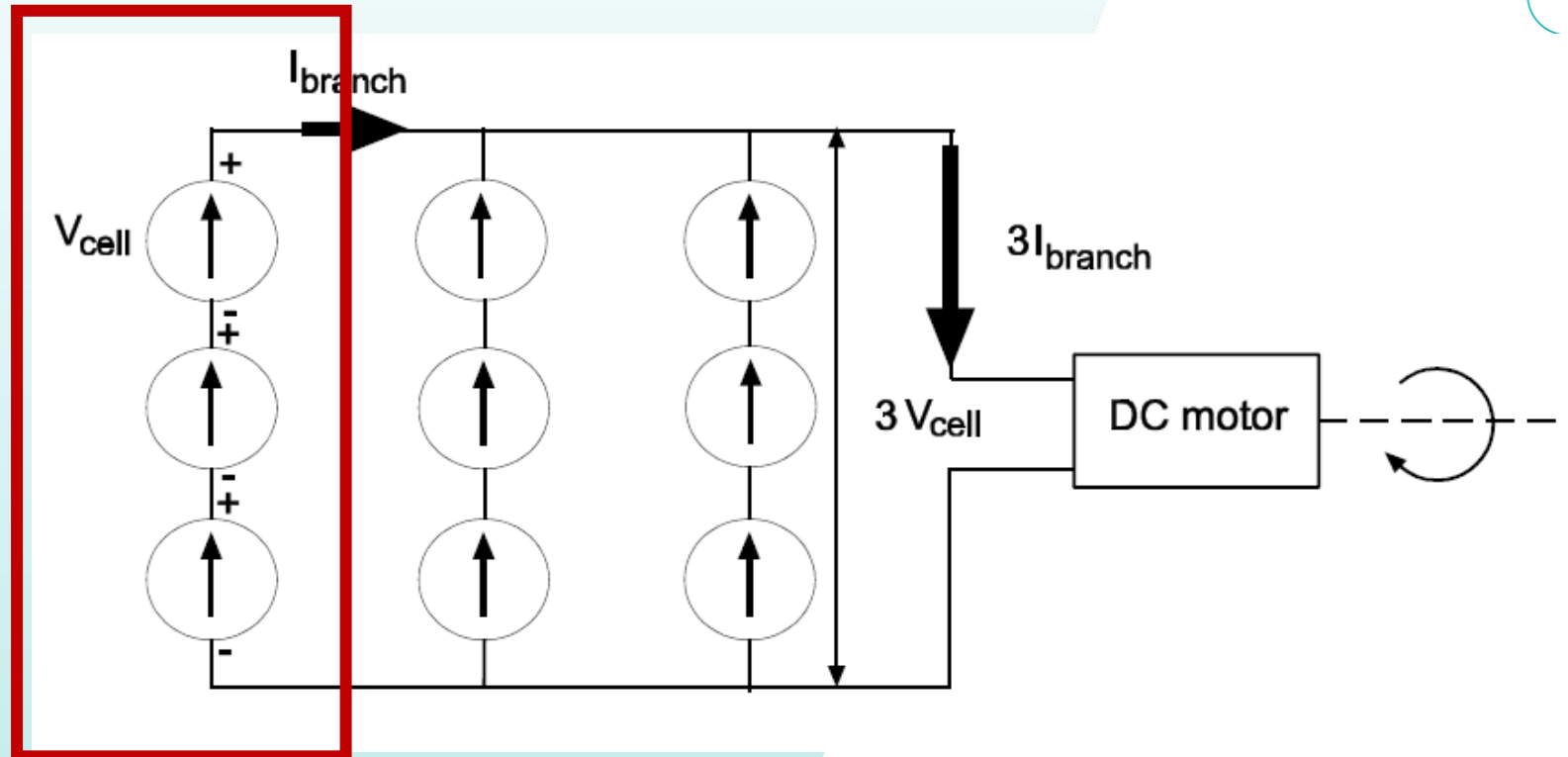



電能

例子

太陽能板陣列的電流:

➤ 3 parallels:

$$= 5 \times 3 \text{ A}$$

$$= 15 \text{ A}$$

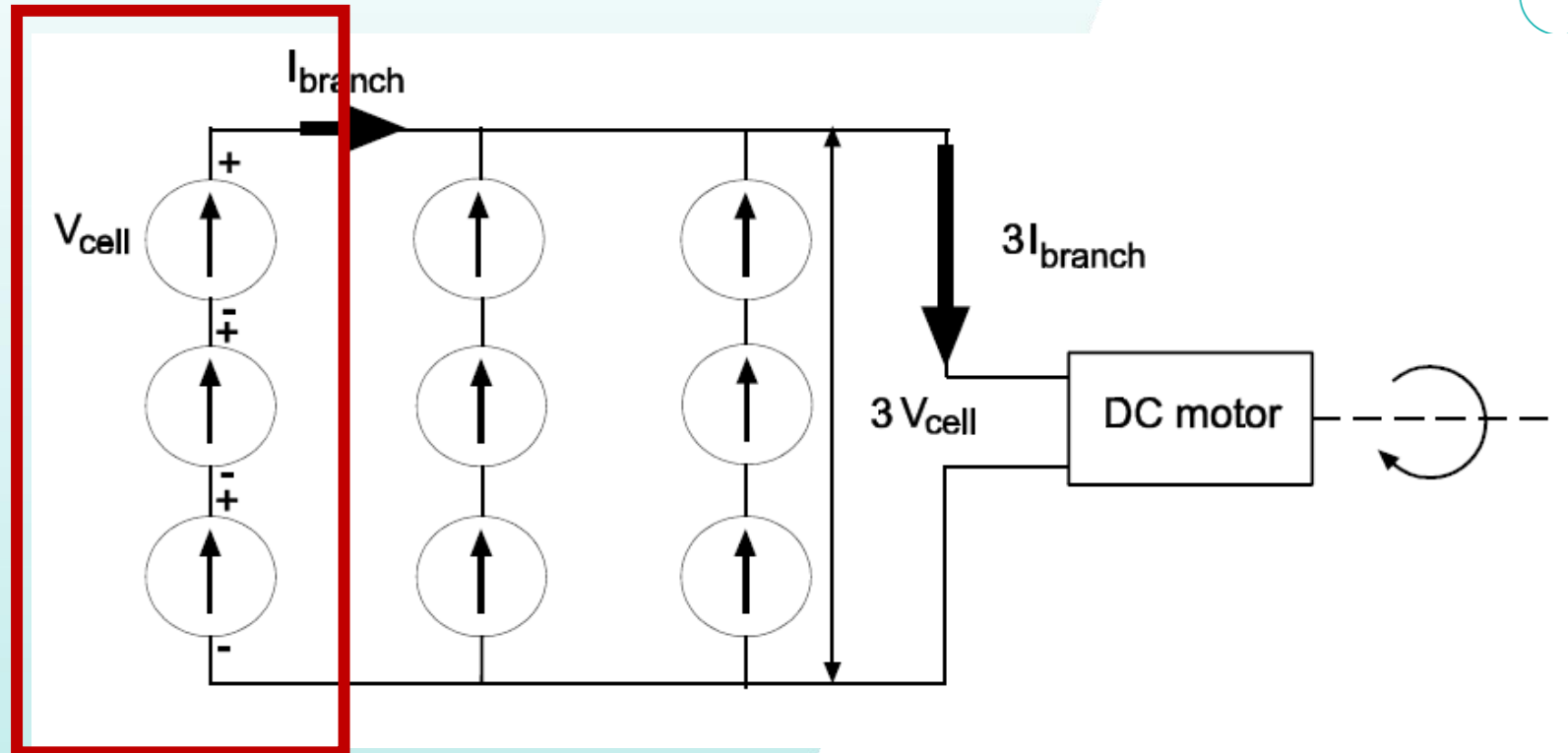



# 電能

## 例子

太陽能板陣列的功率:

➤ Voltage x Current

$$= 1.5 \times 15$$

$$= 22.5 \text{ W}$$

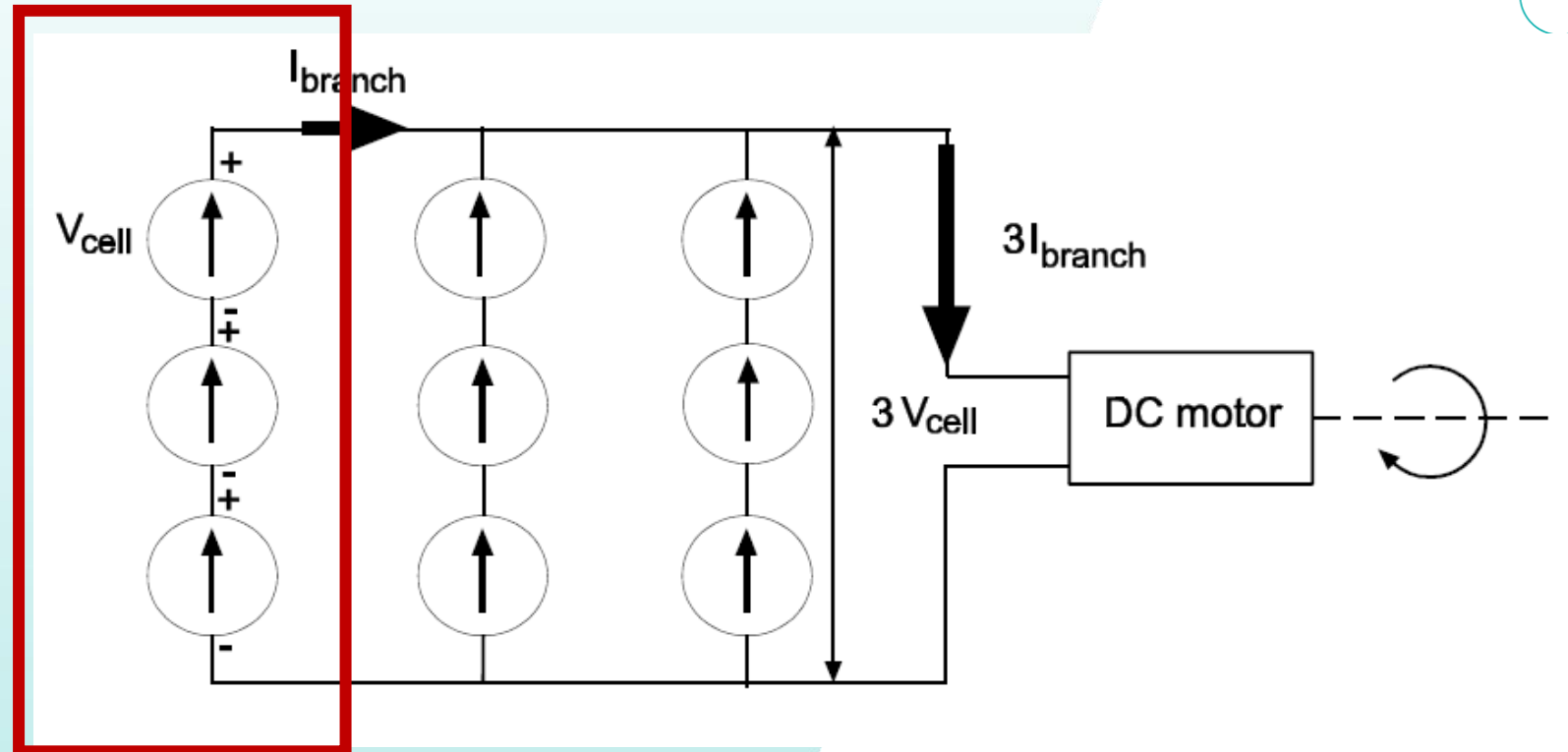

電能

是時候採取行動了：設計你的太陽能車並獲取所需部件！



Chassis, Braking, Solar Panel, Battery pack, Motor.....

## 關鍵問題

- 1) What is the surface of the race like?
- 2) How can you design your car to be aerodynamic?
- 3) What tools might be needed in order to make your design?



**SOPHIE**



完

