



Engineering
工程

SOPHIE



開啟淨零, 可持續發展進程

**「新能源新世代2024」
可載人太陽能車(大車) 工作坊三
電力驅動技術**

工作坊內容

01

1)初談高效節能設計
1月27日



02

車輛動力ABC
2月24日



03

電力驅動技術
3月16日



04

車身設計大不同
7月6日



05

太陽能車攻略
7月13日

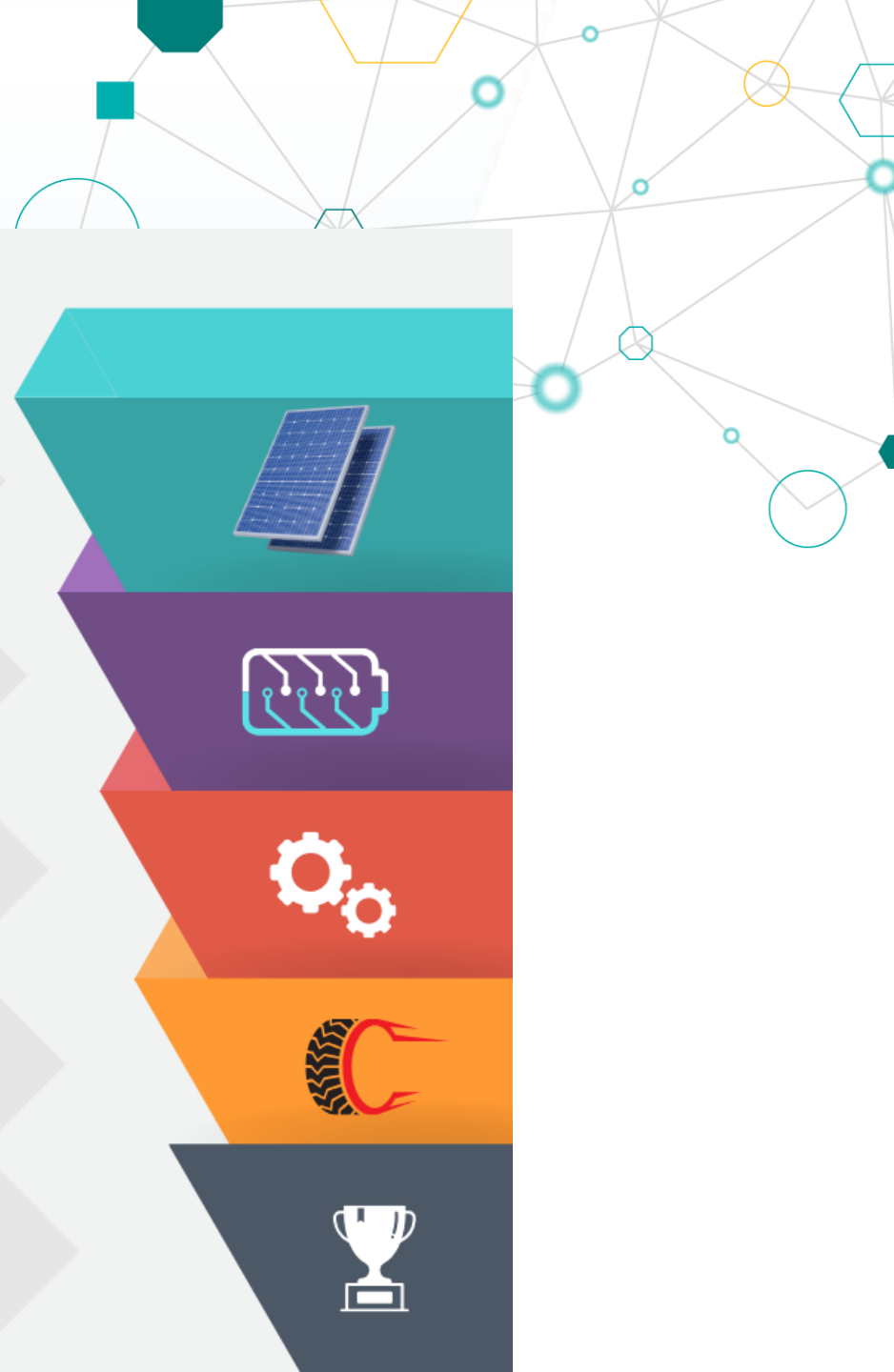

主題

電力驅動技術

- 1) 動力總成
- 2) Energy storage and motor system
- 3) E-mobility
- 4) Typical questions





Power Train exploration

3 wheels:

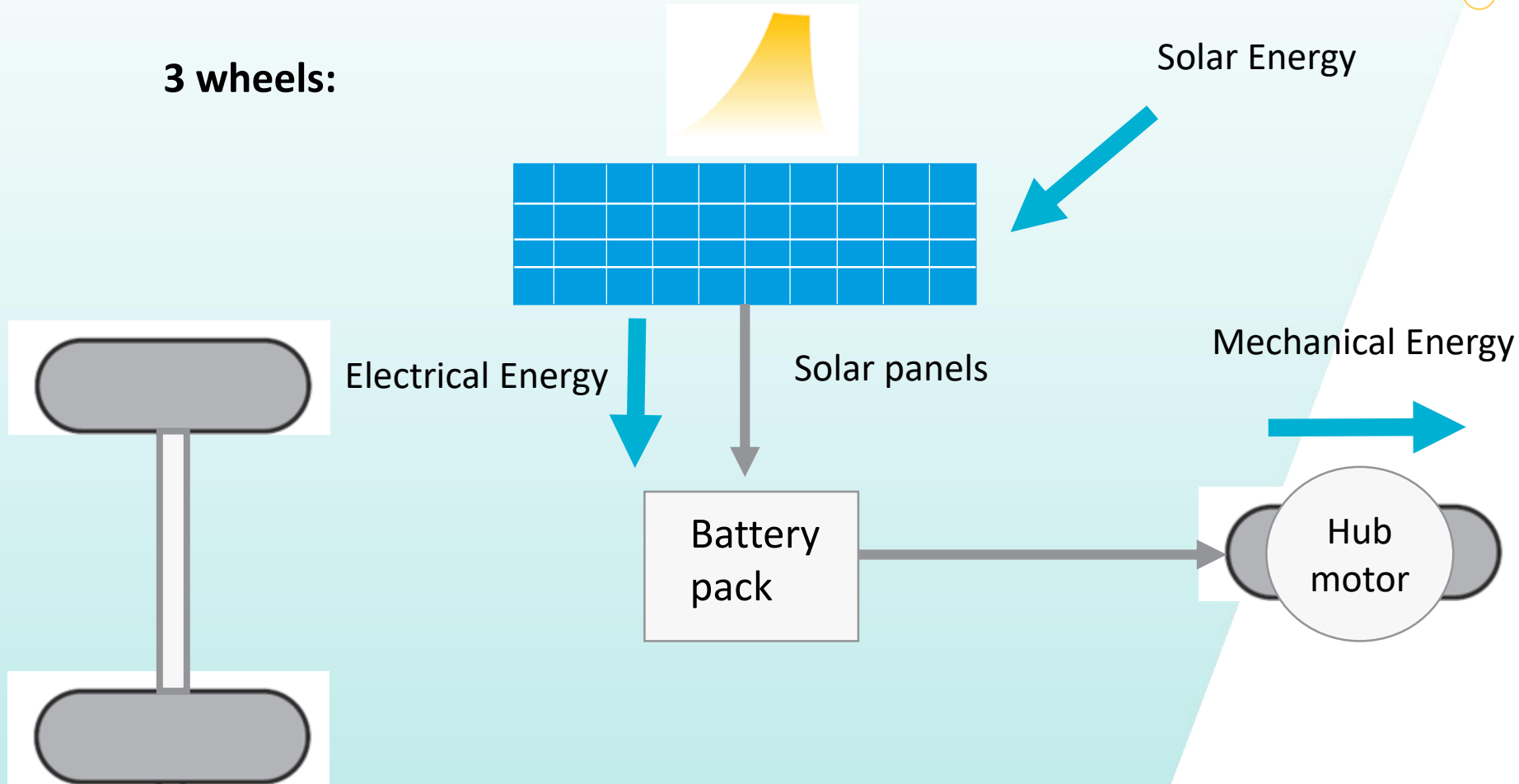



Power Train exploration

3 wheels:

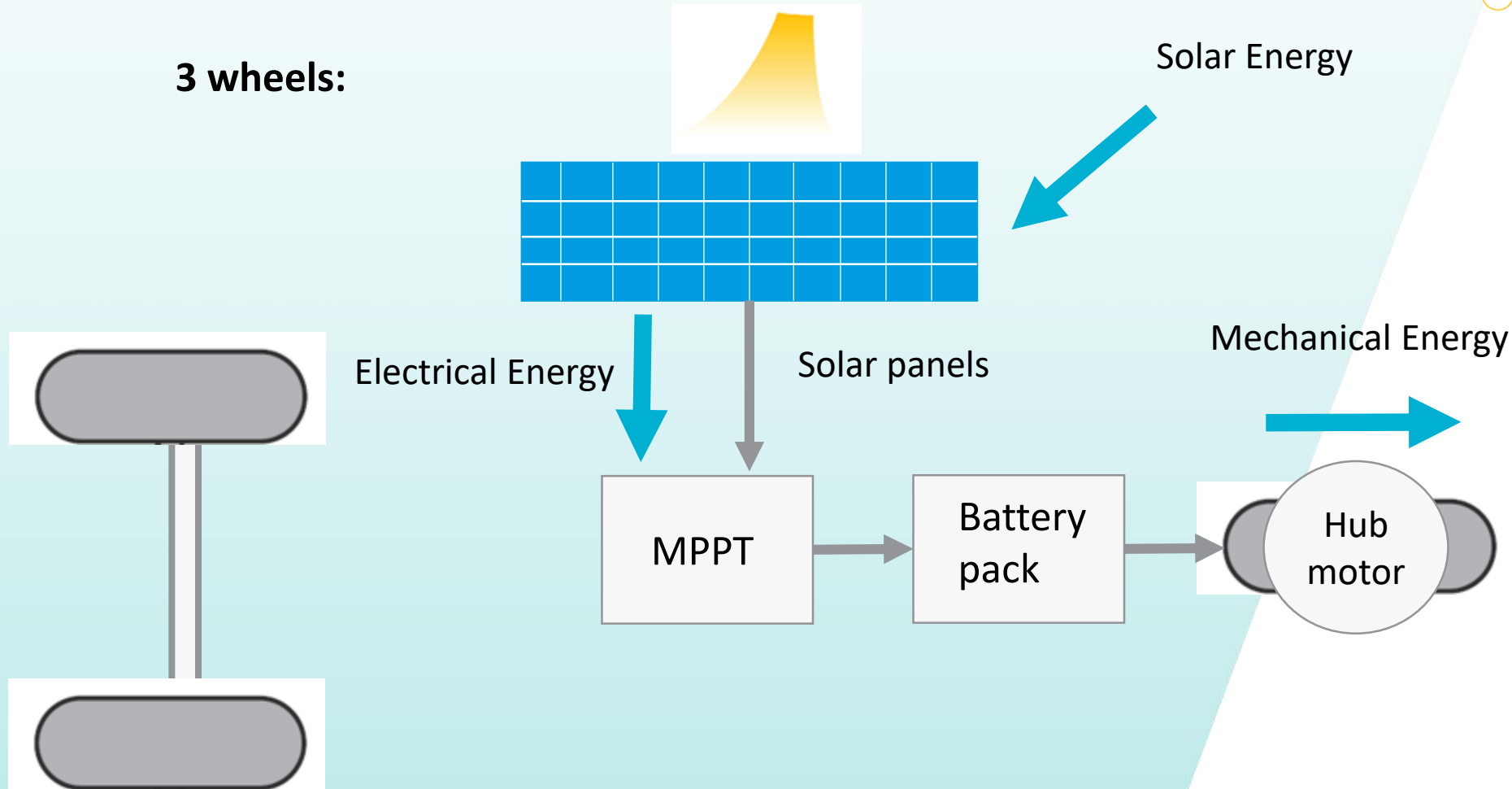

Power Train exploration

4 wheels:

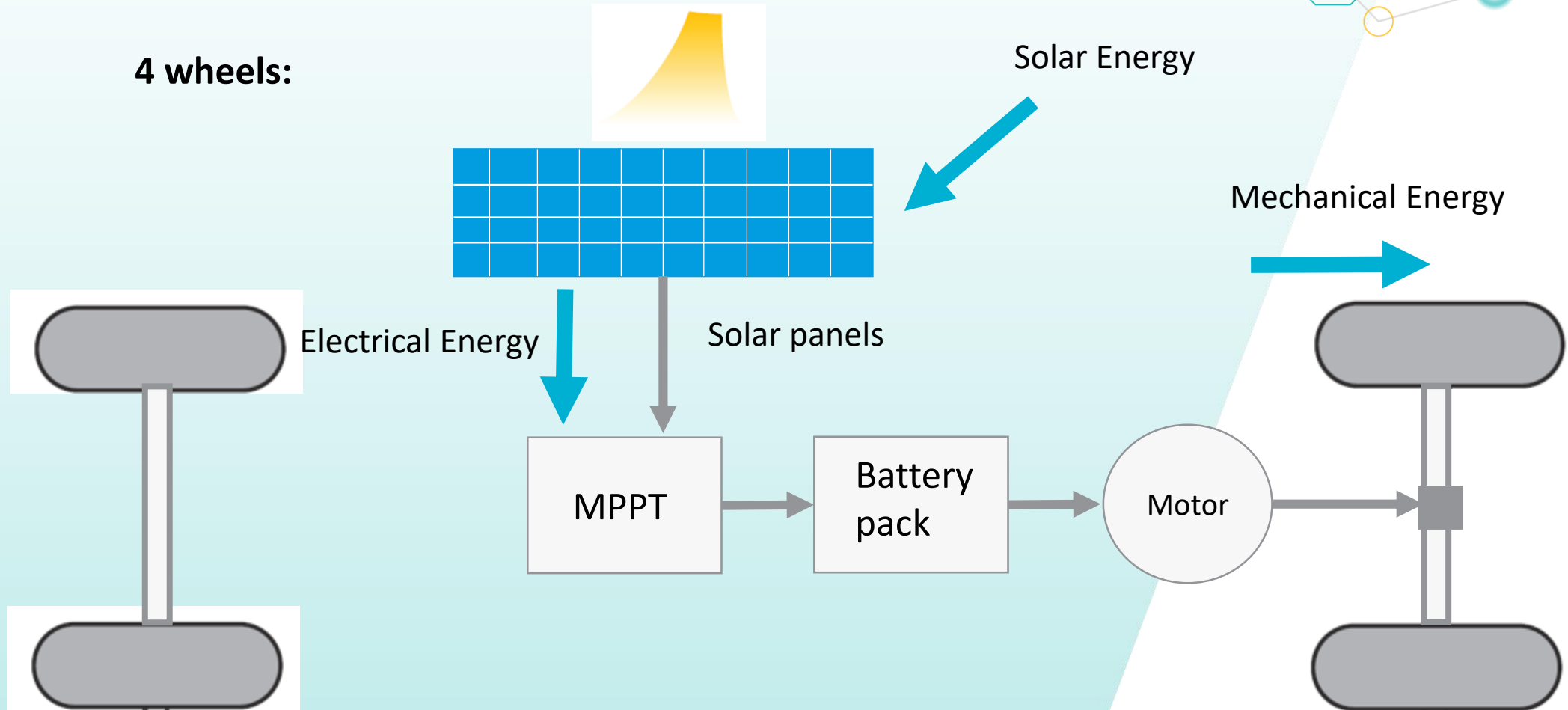

Power Train exploration

Bad example:

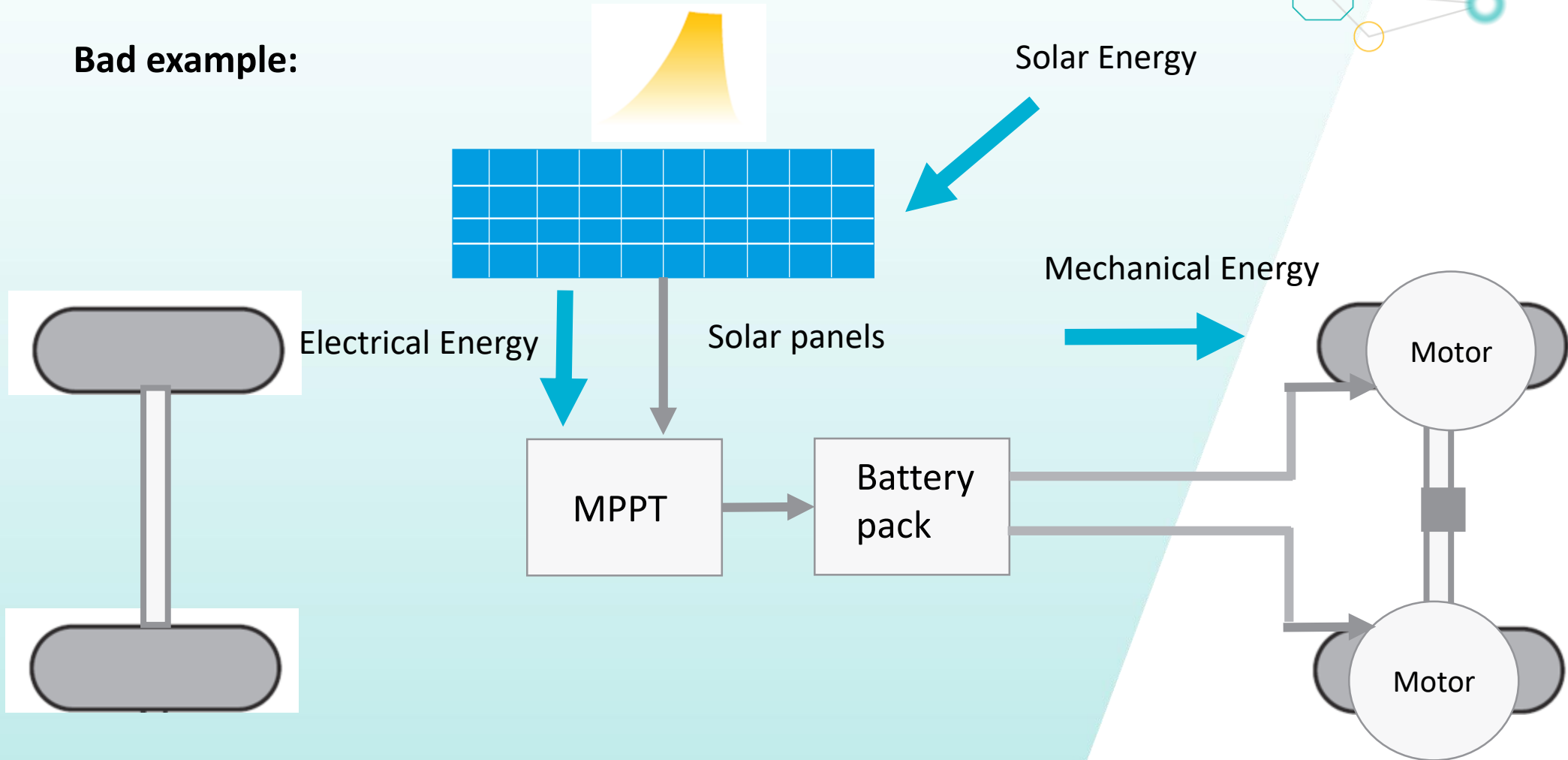

Power Train exploration

If one motor is not working:

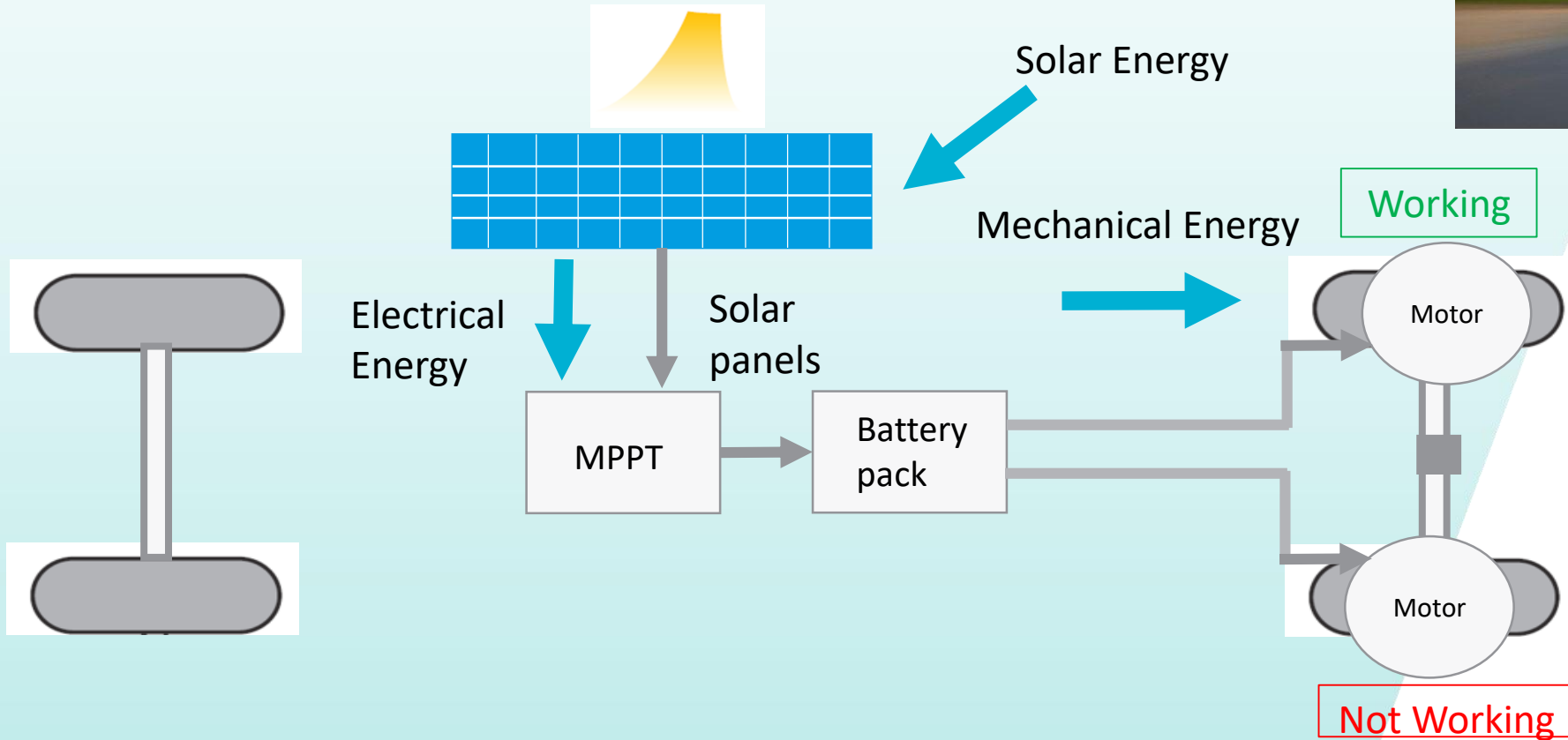

Energy storage and motor system

輸入功率

Input Power

太陽能板 → 電池 → 馬達

輸出功率

Output Power

滾動阻力
空氣阻力
加速

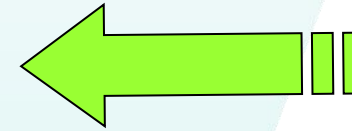

Energy storage and motor system

Power System Schematic

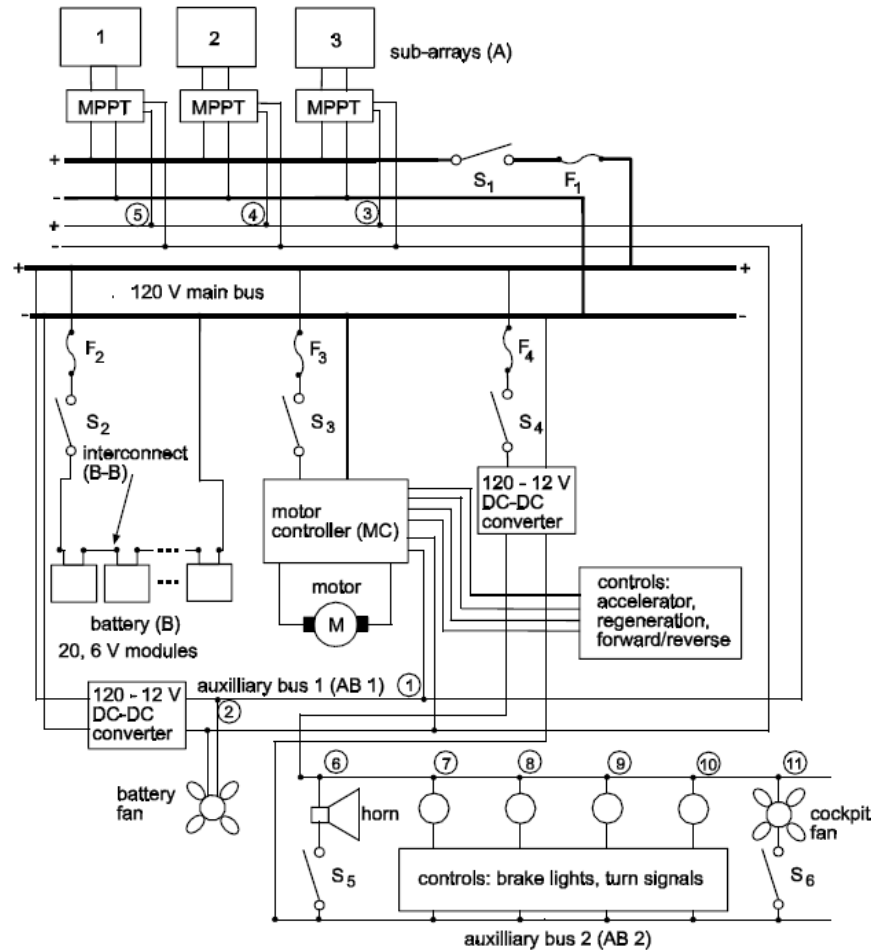

Power Sources:

1. Solar cell array giving 9 A, 120 V, (standard conditions);
2. 20, series-connected, 6-V, Ag-Zn batteries.

Energy storage and motor system

Major Batteries developed for EVs

	Specific energy (Wh/kg)	Specific power (W/kg)	Cycle life (cycles)	Cost (USD/kWh)
VRLA	30–45	200–300	400–600	150
Ni-Cd	40–60	150–350	600–1200	300
Ni-MH	60–120	150–400	600–1200	200–350
Zn/air	230	105	NA	90–120
Na/S	100	200	800	250–450
Li-ion	90–160	250–450	1200–2000	600–1000

Energy storage and motor system

Storing Electric Energy (1):

Storage Methods. All autonomous cars must use propulsive energy stored in the car. Vehicles using *chemical* storage run on the energy stored in gasoline or other hydrocarbon fuels.

Solar energy can be stored in several ways: by *sensible* storage (heating a mass), by *phase change* storage (melting a substance) by *electrochemical* storage or *capacitive* storage (conversion to electric energy and storage in a battery or capacitor, respectively), or by *flywheel inertial* storage (converting electric energy to rotational kinetic energy and storing it in a spinning flywheel).

Note that inertial storage is intrinsic to all vehicles because each stores kinetic energy in its own mass and the rotating masses of its wheels and drive.



Energy storage and motor system

Battery connection:

Example:

3.7 Volts x 10 in serial = 37 V

Battery is 2600 mAh

For 3 sets in parallel = 2600mAh x 3 = 7.8Ah

Battery pack capacity(Wh) = 37 x 7.8 = 288.6 Wh

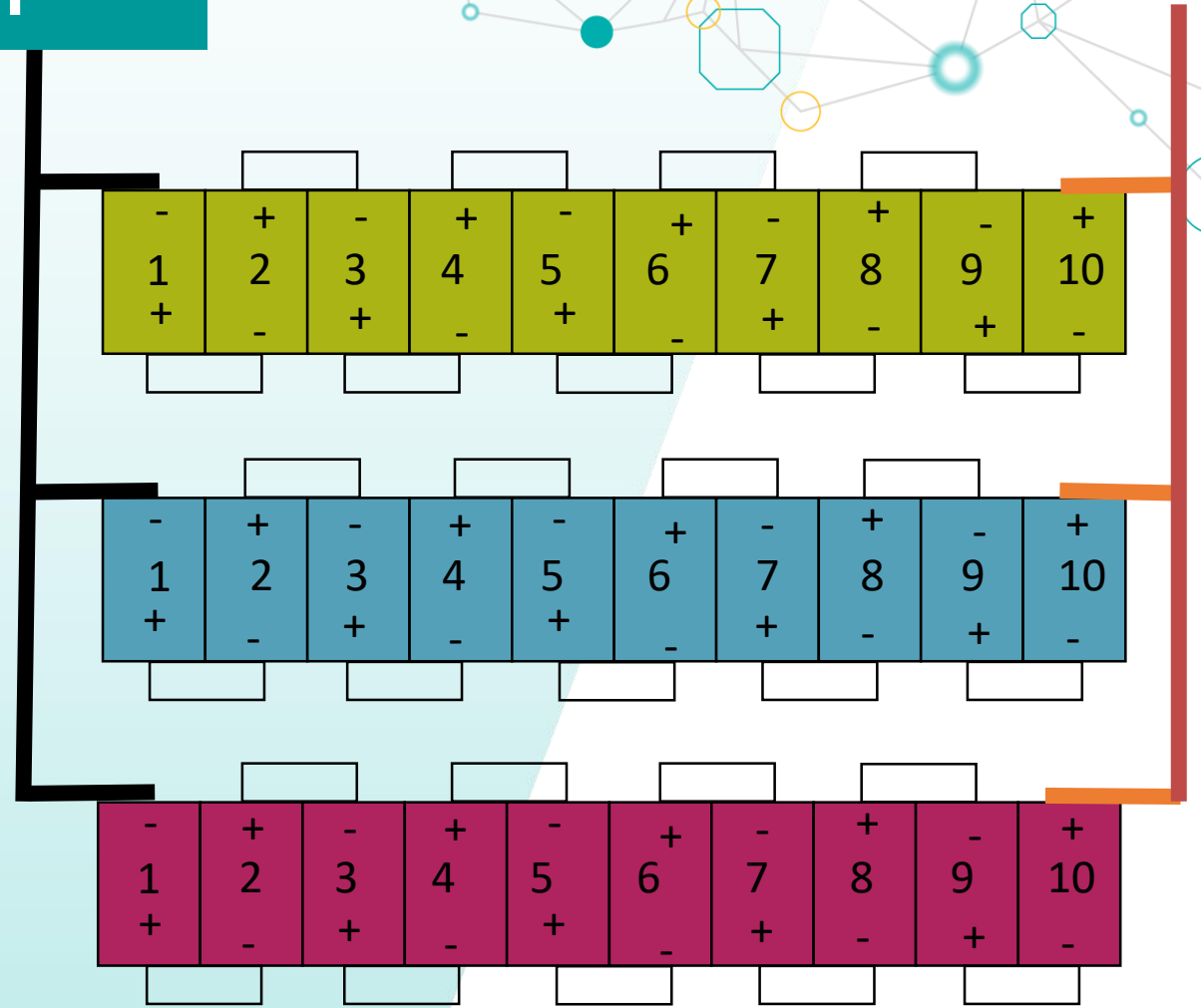

Energy storage and motor system

Energy Source / storage

- Any energy storage device, **must not exceed a nominal voltage of 48 VDC.**
 - The energy storage device, must be **installed outside** of the driver's compartment.
-
- Nominal voltage of battery will be referred to battery specification.
 - According to 4.18.2. The circuit drawing must contain batteries, fuses, circuit breakers, power switchers, solar generator, power trackers, capacitors, motor-controller or chopper, motor(s) and junction cables.
All components (including Battery) in the circuit drawing must be labelled with their detailed electrical specifications.



Energy storage and motor system

Only one propulsion battery and one accessory battery per vehicle are allowed.

Propulsion battery

provide power to the power train

Li-ion battery pack need a Battery Management System (BMS)

Accessory battery

provide power to all safety devices such as, E-stop relay, lighting
cannot be used for cooling systems, electric motors

only one unit



Energy storage and motor system

The energy storage device, including fuel cell, must be equipped with protective measures to **automatically isolate** the said device in the event of **overvoltage, overcurrent, short-circuit, thermal overload and other abnormal operation** of the said device without the need for power other than from the said device.



Energy storage and motor system

Principle of DC machine rotation

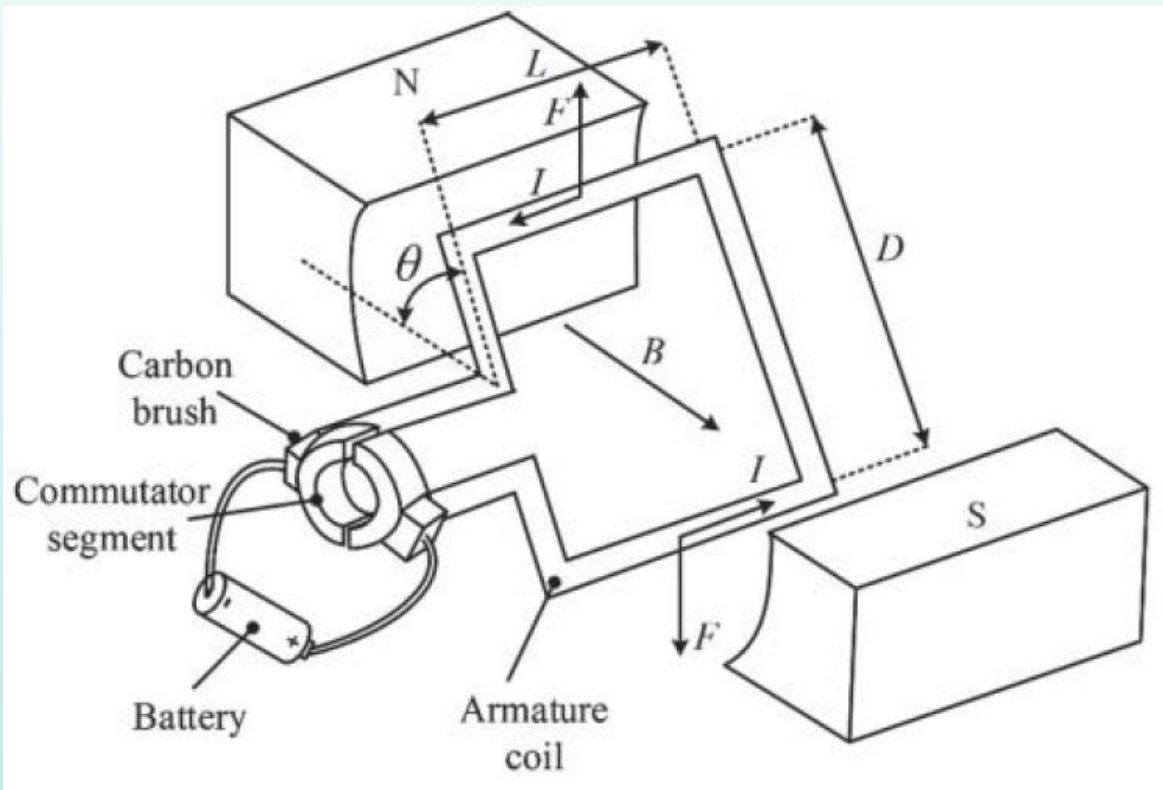

- Electric Current
 - Magnetic Field
- ↓
- Force (Rotation)



Energy storage and motor system

- Electric controller(ESC) is required to keep the motor running which is sometimes more expensive than the motor.

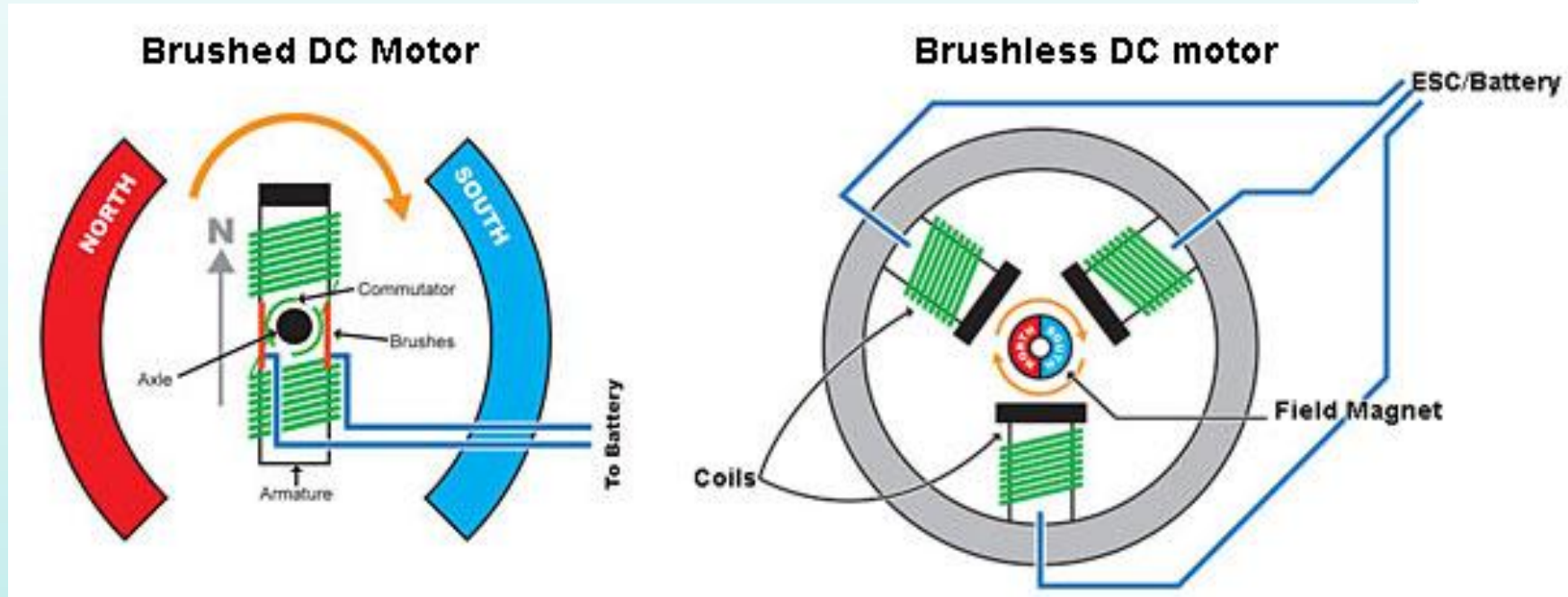

Energy storage and motor system

Motor characteristic curve:

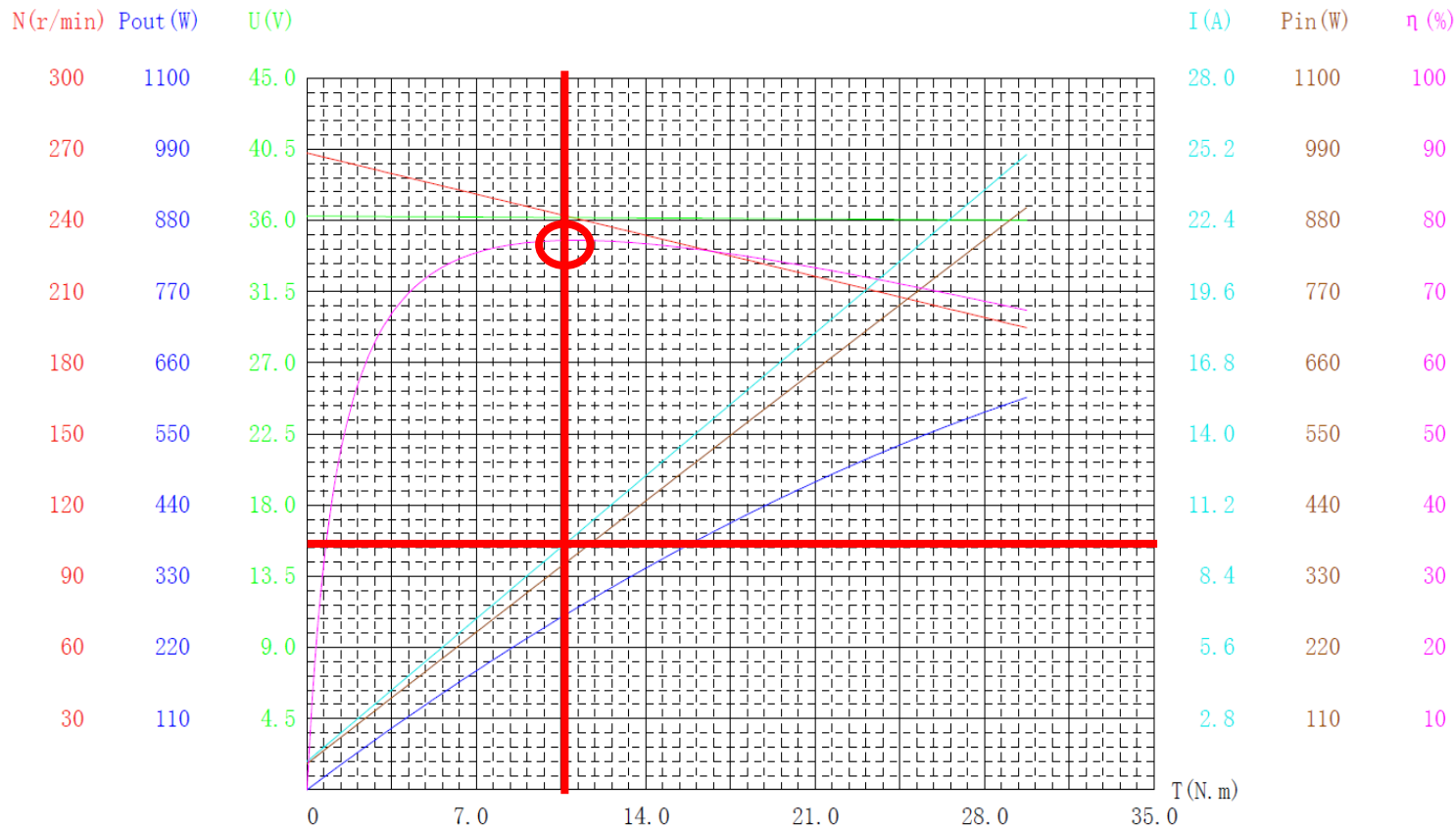

Parameter:

1. N (r/min): Revolution(s) Per Minute
2. Pout(W): Power output
3. U(V): Motor voltage
4. I(A): Motor current
5. Pin(W): Power input
6. η (%): Motor power efficiency



Energy storage and motor system

Recall Lesson 1:

$$P = V \times I = T \times rpm$$

$$P_{in} = V \times I = 358.2 \text{ W}$$

$$P_{out} = P_{in} \times \eta$$

$$= 358.2 \times 0.772$$

$$= 276.5 \text{ W}$$

$I = 9.95 \text{ A}$, $V = 36 \text{ V}$, and $\eta = 77.2 \%$

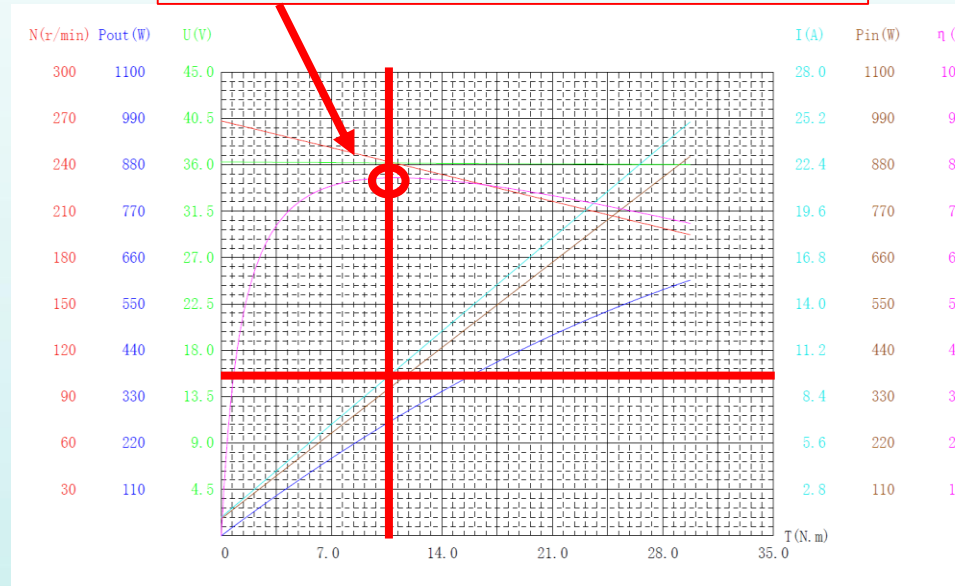

Parameter:

- | | |
|---------------|--------------------------|
| 1. N (r/min): | Revolution(s) Per Minute |
| 2. Pout(W): | Power output |
| 3. U(V): | Motor voltage |
| 4. I(A): | Motor current |
| 5. Pin(W): | Power input |
| 6. η (%): | Motor power efficiency |
| 7. T(N.m.) | Torque |



Energy storage and motor system

Why in-wheel motor?

- high torque
- fast response
- gearless operation
- zero transmission loss



Energy storage and motor system

Motor control example:

- On/Off
- Forward/Reverse
- Speed control
- Stop
- Light & horn
- Meter display

MagicPie-3 or Smart-Pie Kit

Wiring Layout



Black + Red + Yellow Wire (for PAS)

- +5V
- Ground (Battery -)
- Program Signal/Reverse
- Pedelec Signal

Black + Blue Wire (Forward/Reverse Switch)

Connector Pin Definition

- Ground (Battery -)
- Brake Signal
- +5V
- Battery +
- Throttle Signal
- Ground (Battery -)
- Lighting Feed
- Ground (Battery -)
- Horn
- Battery +
- Ground (Battery -)
- Cruise Signal
- Ground (Battery -)
- Brake Signal

to battery pack

- Battery +
- Battery -

Power & Mechanical Brake Lever

Cruise Speed Setting & Horn Button

Throttle/Light Button & Battery Level Indicator

Power & Mechanical Brake lever

4 easy plugs (water-proof)

USB Programming Interface (shared port)

- Throttle Signal
- +5V
- Not Used
- Battery +
- Program Signal/Reverse
- Ground (Battery -)
- Brake Signal
- Cruise Signal

Signal Receive

- Signal Transmisson
- Not Used
- Battery +
- Ground (Battery -)

For Meter Display

Horn -

- Lighting Ground -
- Horn +
- Lighting feed +

to horn **to light**

www.goldenmotor.com

小休



E-Mobility

How about your project progress?

- What is your designed external dimension?
- Which type of chassis do you choose?
 - Monocoque
 - Space frame/ I beam
- Hand-made or purchase
- Delivery date of the key component?



E-Mobility



Flat Surface



Sheet metal?
Thin Balsa wood?

E-Mobility



E-Mobility



E-Mobility



E-Mobility





Typical questions

1. Any allowance for the limit of external dimension?

(Regulation 3. Car design 3.1 Dimensions)

Dimension	Limits
Max. Height	1300mm
Max. Width	1300mm
Max. Length	3500mm
Track width	50% of width
Wheelbase	>1200mm
Ground clearance	>100mm
Max. vehicle weight (without driver)	225 kg

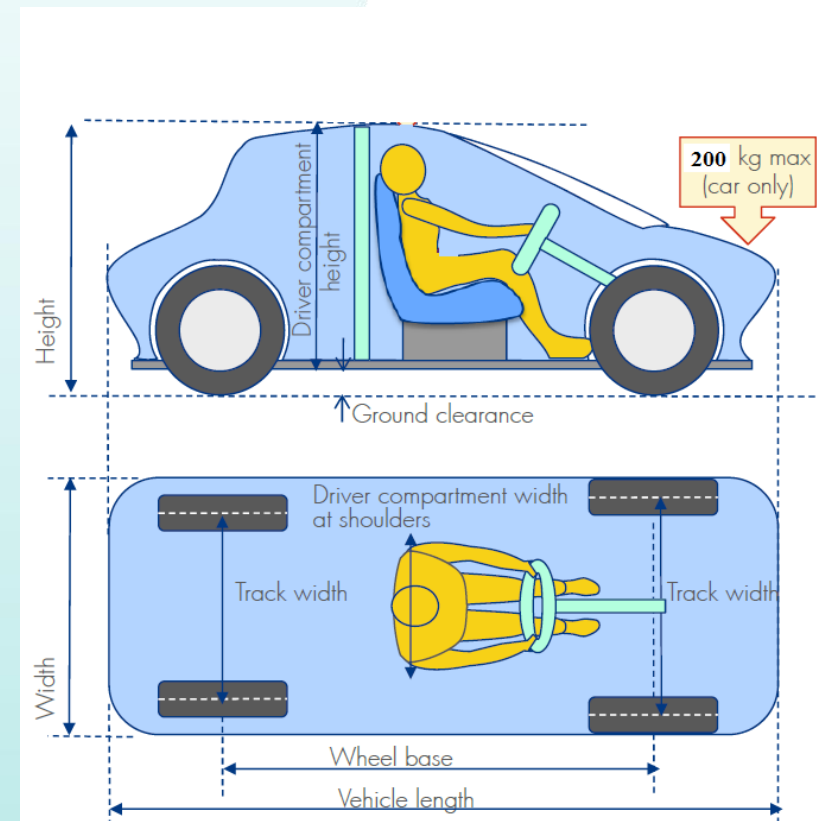

Typical questions

2. Solar Panel limitation:

(Regulation 4.2 Solar Panel)

Maximum allowable solar collector with **Silicon solar cells** is 1.0 m^2 .

GaAs solar cells, the maximum solar collector array will be reduced to 50 per cent of the maximum solar collector area specified for Silicon solar cells

A-300 SOLAR CELL MONO CRYSTALLINE SILICON

Physical Characteristics

Construction:	All-back contact
Dimensions:	125 mm x 125 mm - nominal
Thickness:	270 μm \pm 40 μm

ELECTRICAL CHARACTERISTICS OF TYPICAL CELL AT STANDARD TEST CONDITIONS (STC)

STC is defined as: irradiance of $1000\text{W}/\text{m}^2$, spectrum AM 1.5g and cell temperature of 25°C

Open Circuit Voltage:	0.670 V
Short Circuit Current:	5.9 A
Maximum Power Voltage:	0.560 V
Maximum Power Current:	5.54 A
Rated Power:	3.1 W
Efficiency:	Up to 21.5 %

Temperature Coefficients

Voltage:	-1.9 mV / $^\circ\text{C}$
Power:	-0.38 % / $^\circ\text{C}$

Typical questions

MPPT converter

Example:

We have 2 set of 50 W 18V,
2 set of 150W 24V.

At least 2 set of MPPT converter need.

The converter can only work under same voltage level.

Most efficient way is series the solar panels/ separate with converter.

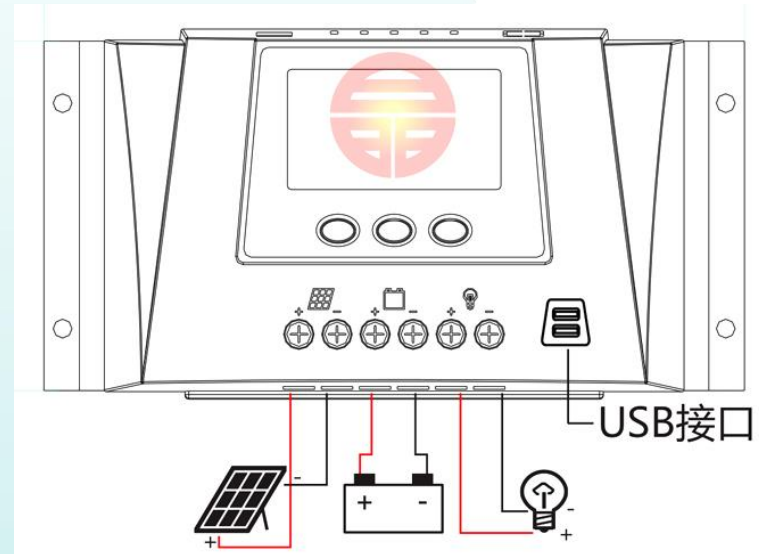



Typical questions

3. Brake:

Two independently triggered braking systems commanded by one single command unit, e.g. a foot pedal or lever, must be installed onto the vehicle.

2

**Independent
Braking
System**

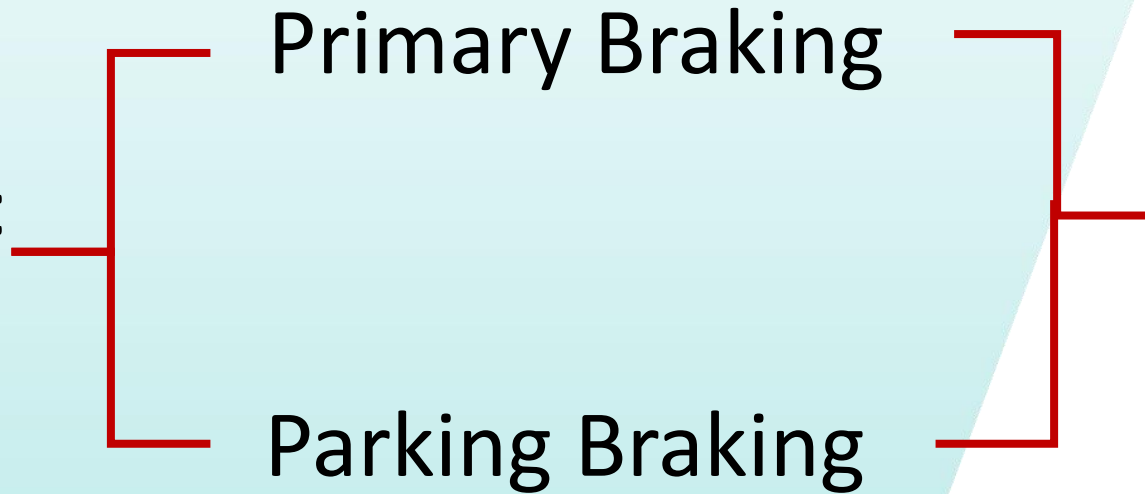

**Ensure the
car can **STOP**
moving!
Even one of
them **FAIL!****

Typical questions

Each braking system must NOT act on only one side of wheels.

Caution: Each system must NOT act only one side of wheels

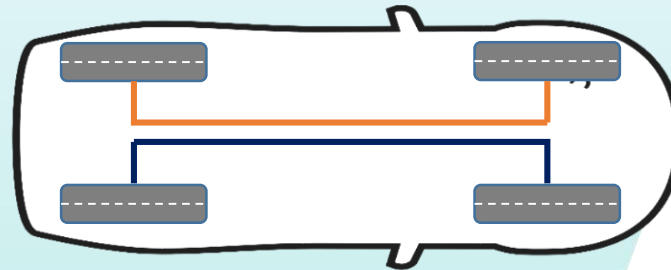

Typical questions

4. Light fitting

- Headlights in white color
- Front and rear turn indicators
In amber color
- Stoplights in red color

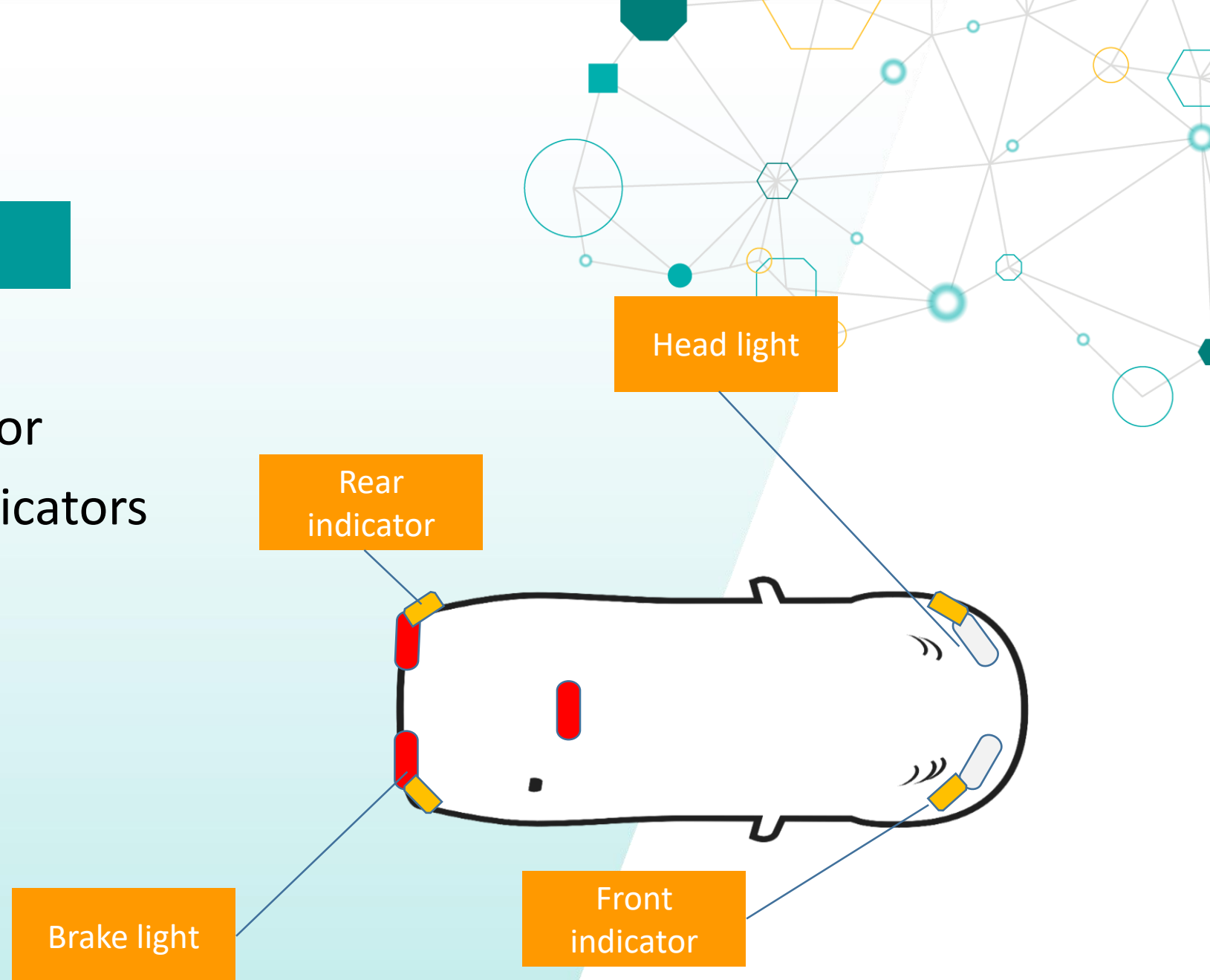



Typical questions

5. Seat belt installation (at least 5-points)

2.16 Safety Belts

a)	The Driver's seat must be fitted with an effective safety harness with at least five mounting points to maintain the Driver securely in his/her seat. The five independent belts must be firmly attached to the vehicle's main structure and be fitted into a single buckle, specifically designed for this purpose.
b)	The safety harness must prevent any upward or forward motion of the Driver's torso. The adjustor must be located as close as possible to the connection point. The crotch strap mounting point must be underneath the body, and the topmost straps should be mounted 0° to 10° below the top of the Driver's shoulder.

Typical questions

6. Steering rack



Typical questions

2.22 Fire Extinguisher

a)	Each vehicle must be fitted with a 1kg fire extinguisher within the cockpit and be accessible to the Driver. These should be securely mounted to prevent movement while driving / braking. All Drivers must be trained in the use of said fire extinguisher.
b)	The extinguisher must be pressurised to 8 bar minimum and 13.5 bar maximum. The following information must be visible on each extinguisher: capacity, type of fire extinguisher, weight or volume of the fire extinguisher and date the extinguisher must be checked, which must be no more than two years after either the date of filling or the date of the last check.
c)	The extinguishers must be easily accessible for the driver.



Typical questions

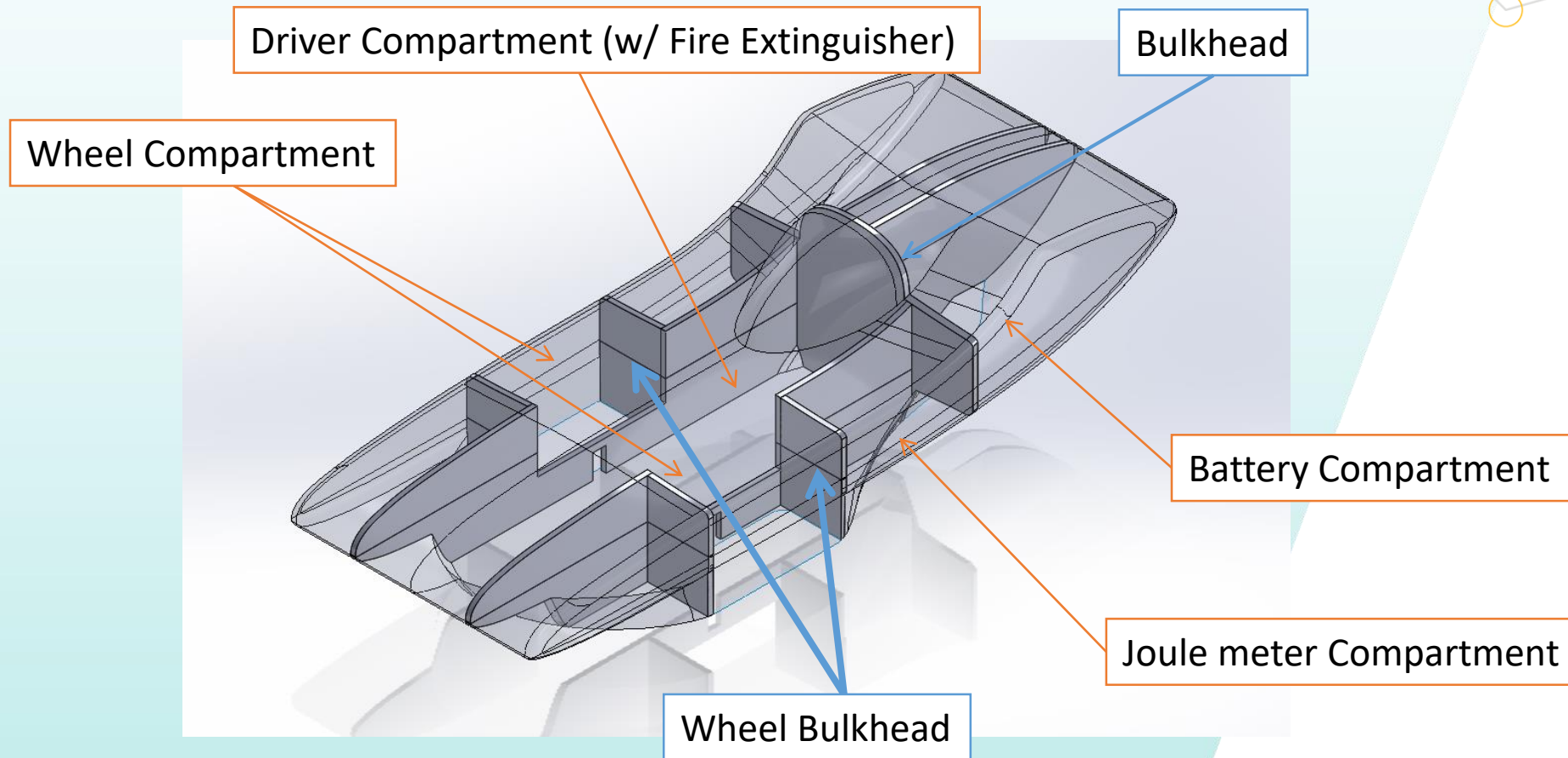

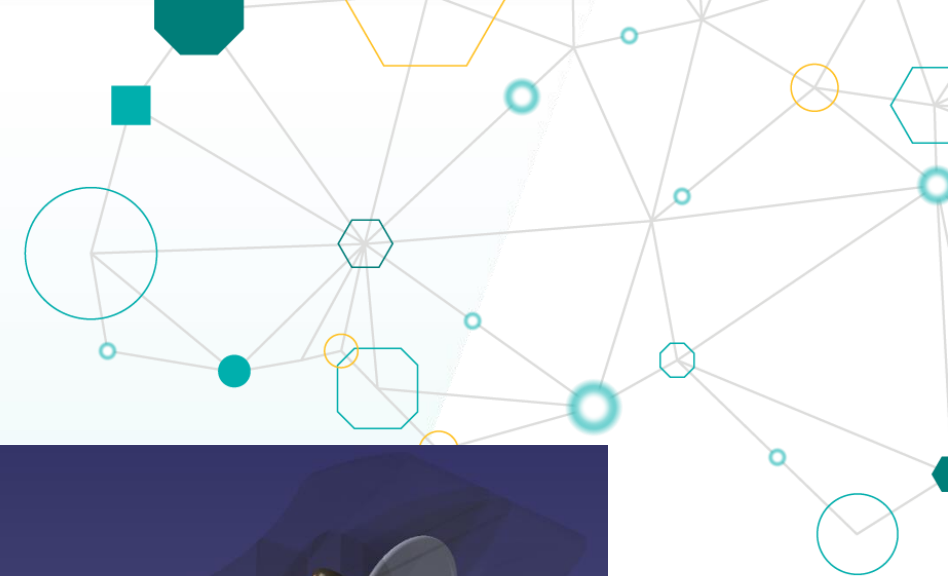

Typical questions

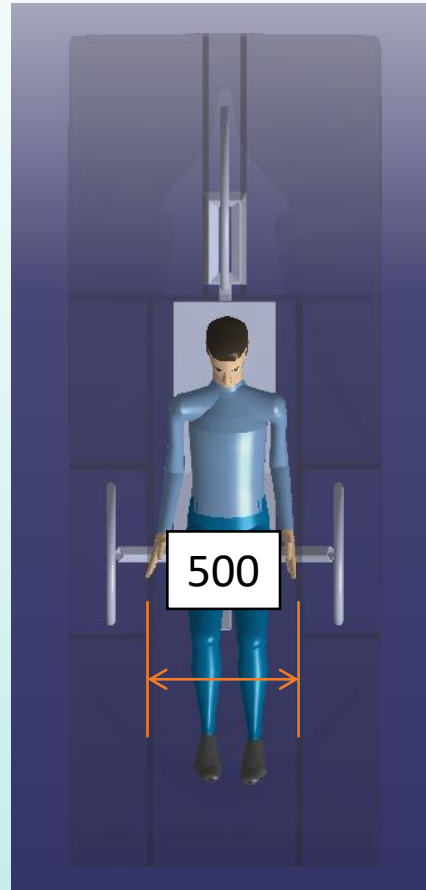
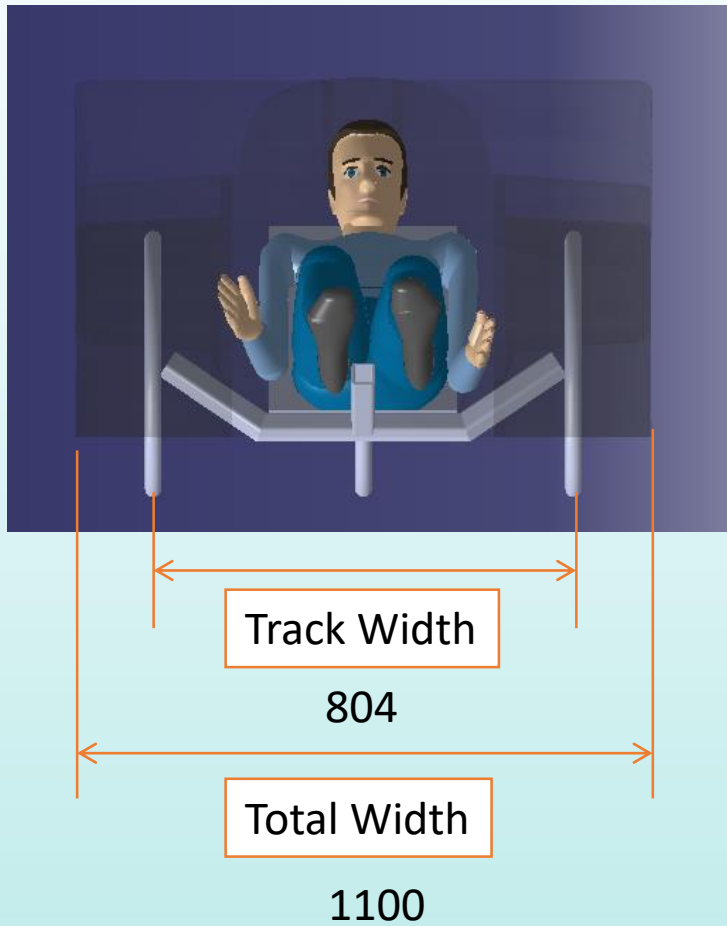

Shell Eco-marathon China 2024



< 2023 Programme



Shell Eco-marathon China 2023

Golden Port, Beijing, China
October 21, 2024



完

